

Parilla X30 J 125cc RL – TaG

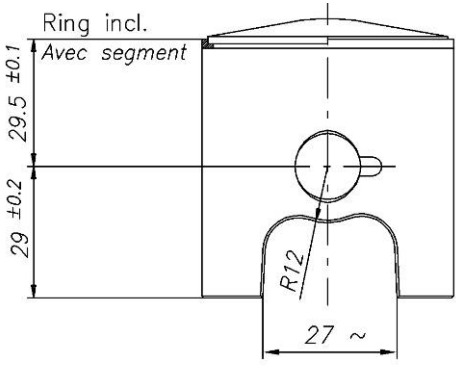
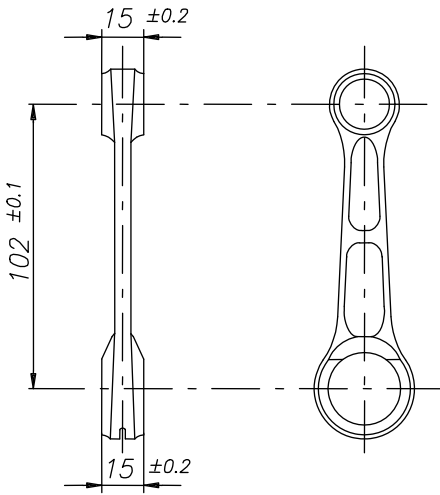
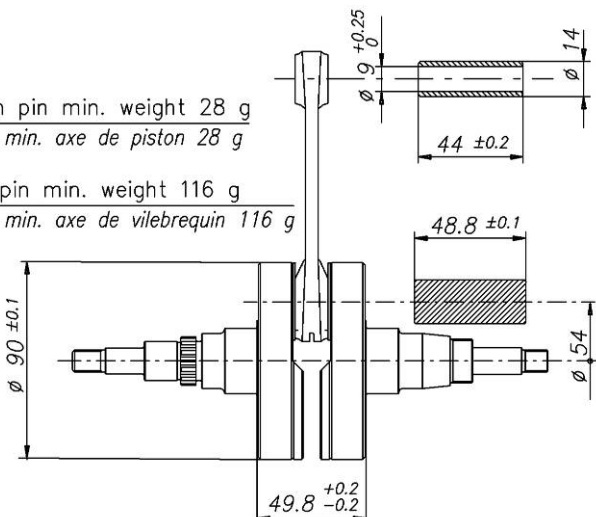
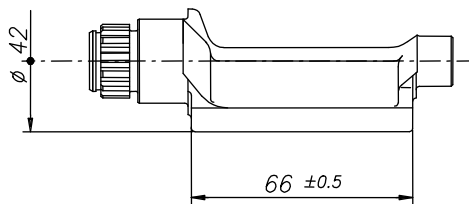

FEATURES - CARACTERISTIQUES

		Cylinder volume <i>Volume du cylindre</i>	123.67 cm ³
		Bore <i>Alésage</i>	54 mm
		Max. theoretical bore <i>Alésage théorique max.</i>	54.28 mm
		Stroke <i>Course</i>	54 mm
		Cooling system <i>Système de refroidissement</i>	Water <i>Eau</i>
		Inlet system <i>Système d'admission</i>	Reed valve <i>À clapets</i>
Carburetor <i>Carburateur</i>	Tryton Hobby 27/C	Cylinder / crankcase transfers n° <i>N° de canaux cylindre / carter</i>	3
Number of piston rings <i>Nombre de segments</i>	1	Inlet / exhaust ports number <i>N° lumières adm. / échapp.</i>	3
Big end conr. ball-bearing diam. <i>Diamètre palier tête de bielle</i>	20x26x15	Combustion chamber shape <i>Forme chambre de combustion</i>	Spherical <i>Spherique</i>
Crankshaft ball-bearing diam. <i>Diamètre palier du vilebrequin</i>	30x62x16	Selettra or PVL ignition <i>Allumage Selettra ou PVL</i>	Digital
Small end conr. ball-bearing diam. <i>Diamètre palier pied de bielle</i>	14x18x17.5	RPM limiter <i>Limiteur de tours</i>	Yes <i>Oui</i>
Distance between conrod centers <i>Longueur (entre axe) de la bielle</i>	102 mm	Generator for battery charging <i>Générateur de recharge batterie</i>	Yes <i>Oui</i>
Balancing shaft <i>Arbre d'équilibrage de vilebr.</i>	Yes <i>Oui</i>	Electric starter <i>Démarrateur électrique</i>	Yes <i>Oui</i>

DESCRIPTION OF THE MATERIAL DESCRIPTION DES MATERIAUX		PISTON	
Conrod material <i>Matériel de la bielle</i>	Steel <i>Acier</i>	 <p>Piston min. weight (ring incl.) 128 g Poids min. piston (avec segment) 128 g</p>	
Crankshaft material <i>Matériel du vilebrequin</i>	Steel <i>Acier</i>		
Balancing shaft material <i>Matériel de l'arbre d'équilibrage</i>	Steel <i>Acier</i>		
Gears material <i>Matériel des engrenages</i>	Steel <i>Acier</i>		
Starter ring material <i>Matériel de la couronne démarr.</i>	Steel <i>Acier</i>		
Head material <i>Matériel de la culasse</i>	Aluminium		DISTANCE BETWEEN CONROD CENTERS <i>ENTRE AXE DE LA BIELLE</i>
Cylinder material <i>Matériel du cylindre</i>	Aluminium	 <p>Min. weight 110 g Poids min. 110 g</p>	
Liner material <i>Matériel de la chemise</i>	Iron <i>Fonte</i>		
Crankcase material <i>Matériel du carter</i>	Aluminium		
Piston material <i>Matériel du piston</i>	Aluminium		
Piston rings material <i>Matériel des segments</i>	Iron <i>Fonte</i>		
Exhaust muffler material <i>Matériel du pot d'échappement</i>	Sheet-steel <i>Tôle acier</i>		
Ball-bearings <i>Roulements</i>	6206 type		
CRANKSHAFT - VILEBREQUIN			BALANCING SHAFT <i>ARBRE D'EQUILIBRAGE</i>
 <p>Piston pin min. weight 28 g Poids min. axe de piston 28 g</p> <p>Crankpin min. weight 116 g Poids min. axe de vilebrequin 116 g</p> <p>Complete crankshaft min. weight 2150 g Poids min. du vilebrequin complet 2150 g</p>			 <p>Min. weight 315 g Poids min. 315 g</p>

CYLINDER DEVELOPMENT - DEVELOPPEMENT DU CYLINDRE

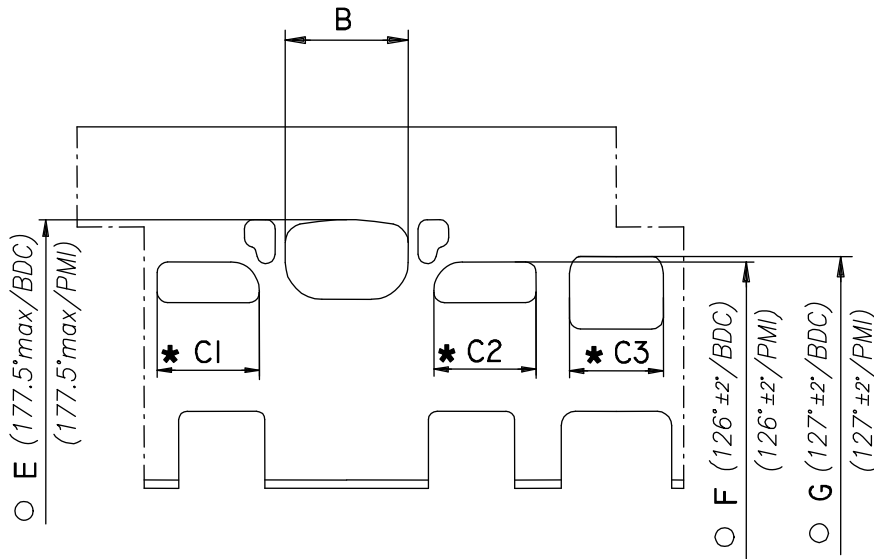

B	$\leq 36.5 \text{ mm}$
CI = C2	$\leq 30 \text{ mm}$
C3	$\leq 28.5 \text{ mm}$
E	177.5° max
F	$126^\circ \pm 2^\circ$
G	$127^\circ \pm 2^\circ$

* CHORDAL READING
LECTURE CORDALE

○ ANGULAR READING BY INSERTING A 0.2 mm GAUGE
LECTURE ANGULAIRE PAR INSERTION D'UNE CALE DE 0.2 mm

CYLINDER BASE VIEW
VUE DE LA BASE DU CYLINDRE

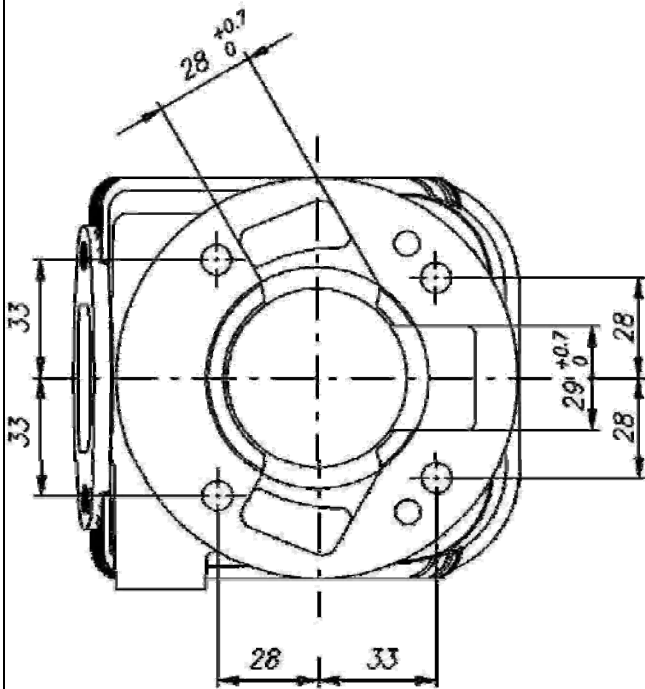

CYLINDER CROSS SECTION VIEW
VUE EN SECTION DU CYLINDRE

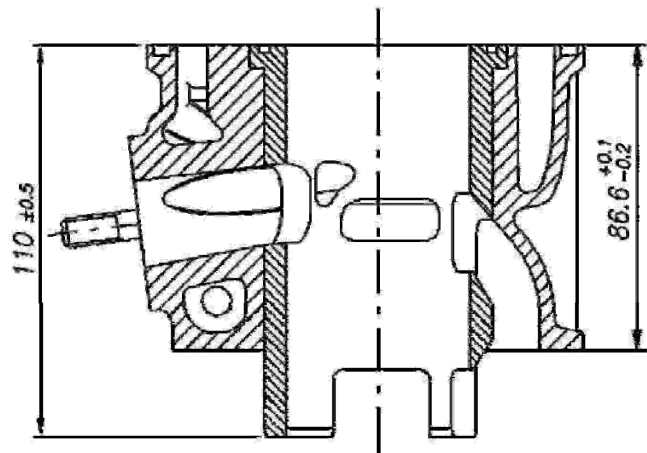

COMBUSTION CHAMBER VIEW
VUE DE LA CHAMBRE DE COMPRESSION

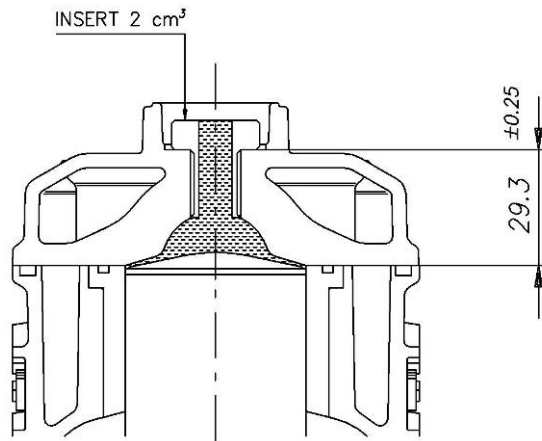

COMBUSTION CHAMBER VOLUME = 9.7 cm³ min.
VOLUME CHAMBRE COMBUSTION = 9.7 cm³ min.

ATT.: SQUISH MIN. = 0.90 mm

CRANKCASE INSIDE VIEW
VUE A' L' INTERIEUR DU CARTER

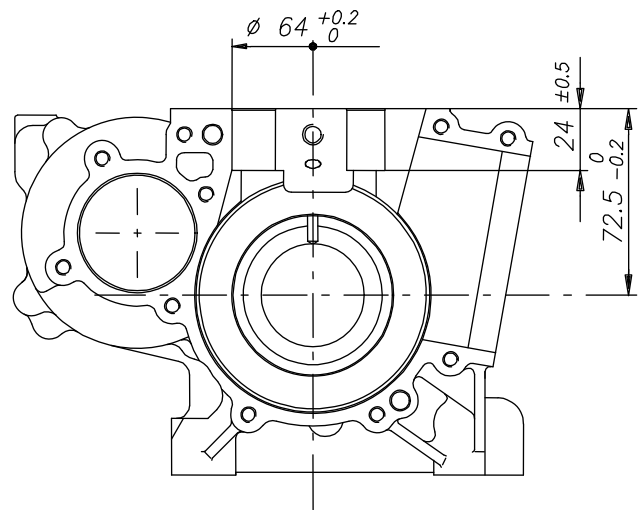

VENTURI CARB. DIMENSIONS
DIMENSIONS DU VENTURI DU CARBURATEUR

Tryton Hobby 27/C

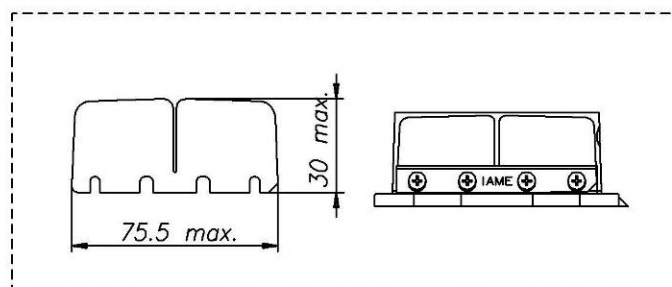
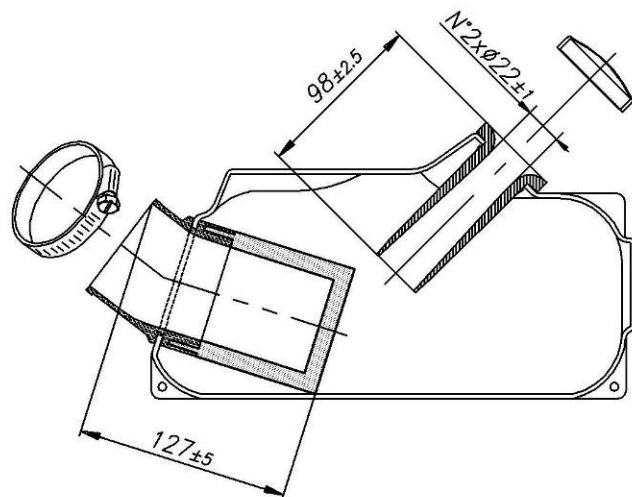
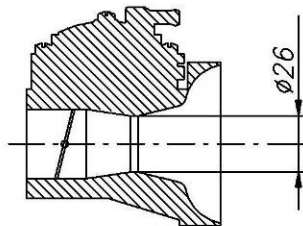

INLET SILENCER
SILENCIEUX D' ASPIRATION

DESCRIPTION OF THE CLUTCH - DESCRIPTION DE L' EMBRAYAGE

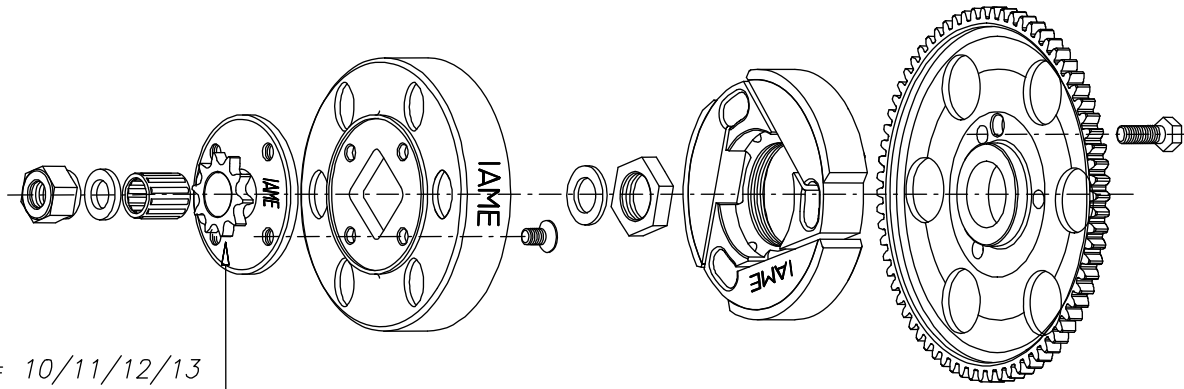

Z= 10/11/12/13

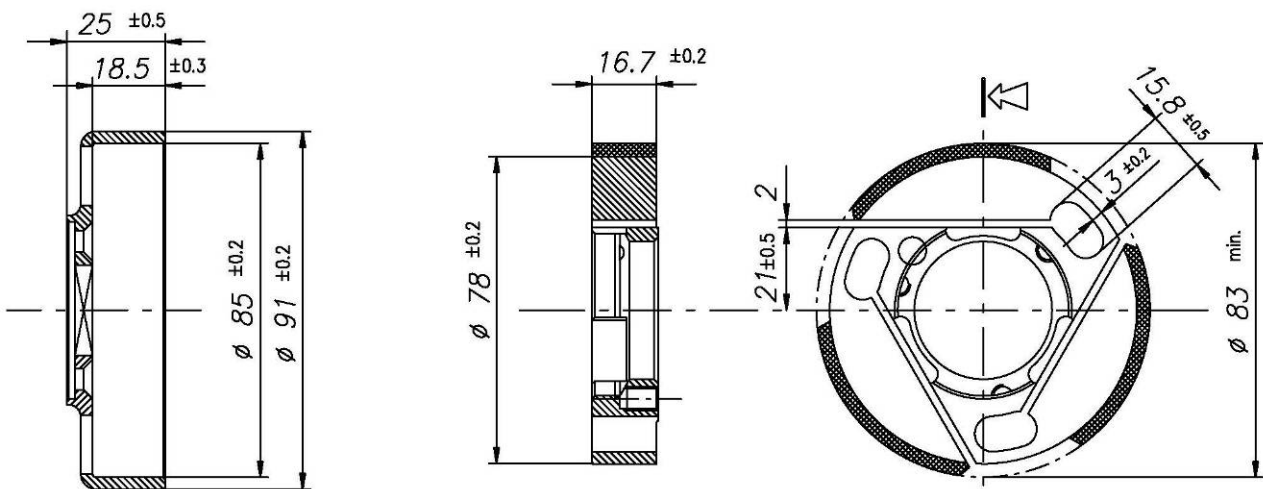

Min. weight 225 g
Poids min. 225 g

Min. weight 360 g
Poids min. 360 g

EXHAUST MUFFLER VIEW AND DIMENSIONS
VUE ET DIMENSIONS DU SILENCIEUX D' ECHAPPEMENT

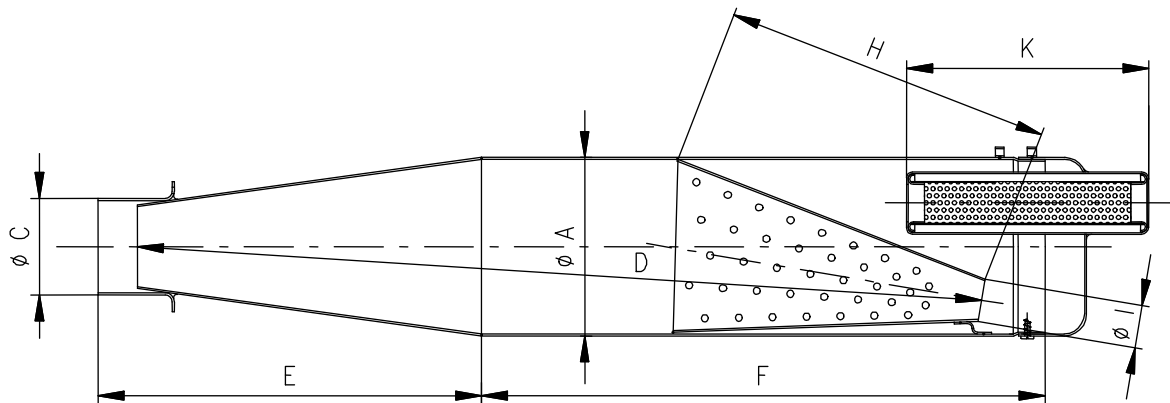

A: 100 ±1 ϕ ext.	E: 218 ±5	H: 180 ±5
C: 54 ±1 ϕ ext.	K: 130 ±3	I: 24 ±2 ϕ ext.
D: 485 ±5	F: 315 ±3	

Min. weight 1.39 Kg
Poids min. 1.39 Kg

WIRING DIAGRAM (SELETTRA DIGITAL "K" IGNITION)
 SCHEMA CIRCUIT ELECTRIQUE (ALLUMAGE SELETTRA DIGITAL "K")

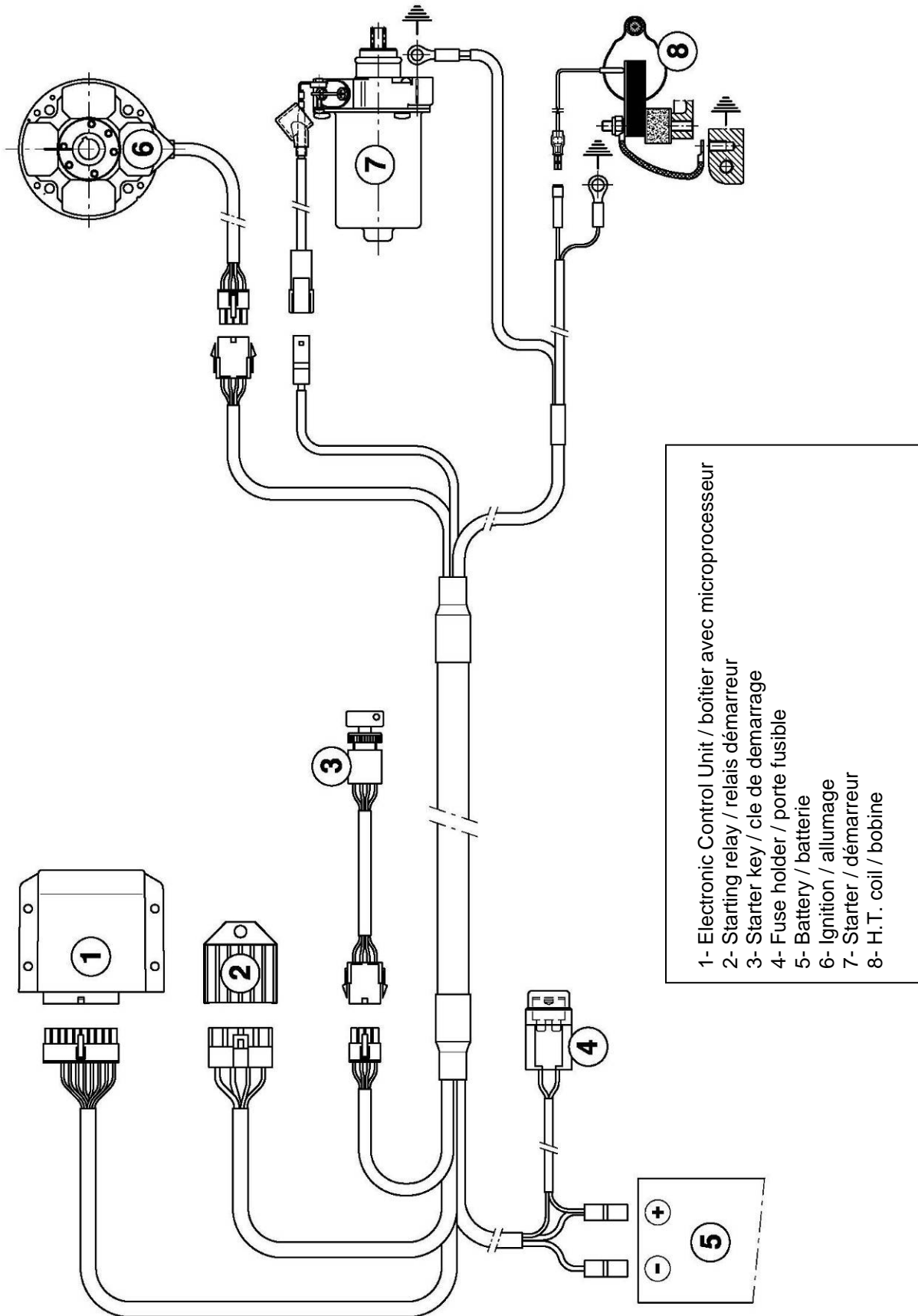

- 1- Electronic Control Unit / boîtier avec microprocesseur
- 2- Starting relay / relais démarrage
- 3- Starter key / cle de démarrage
- 4- Fuse holder / porte fusible
- 5- Battery / batterie
- 6- Ignition / allumage
- 7- Starter / démarreur
- 8- H.T. coil / bobine

WIRING DIAGRAM (PVL IGNITION, 1st TYPE)
 SCHEMA CIRCUIT ELECTRIQUE (ALLUMAGE PVL, 1^{er} TYPE)

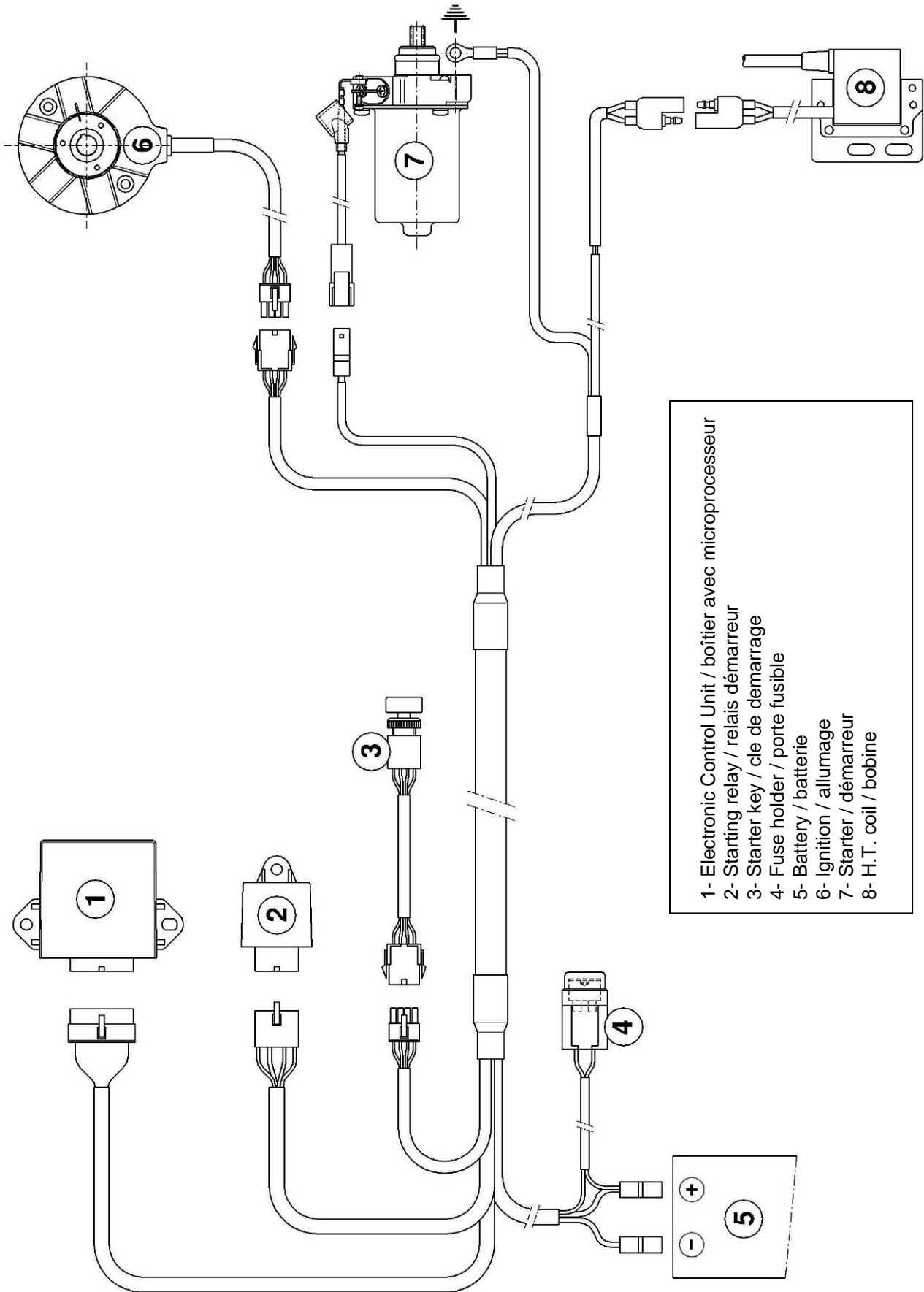

- 1- Electronic Control Unit / boîtier avec microprocesseur
- 2- Starting relay / relais démarrage
- 3- Starter key / cle de démarrage
- 4- Fuse holder / porte fusible
- 5- Battery / batterie
- 6- Ignition / allumage
- 7- Starter / démarreur
- 8- H.T. coil / bobine

WIRING DIAGRAM (PVL IGNITION, 2nd TYPE)
 SCHEMA CIRCUIT ELECTRIQUE (ALLUMAGE PVL, 2^{ème} TYPE)

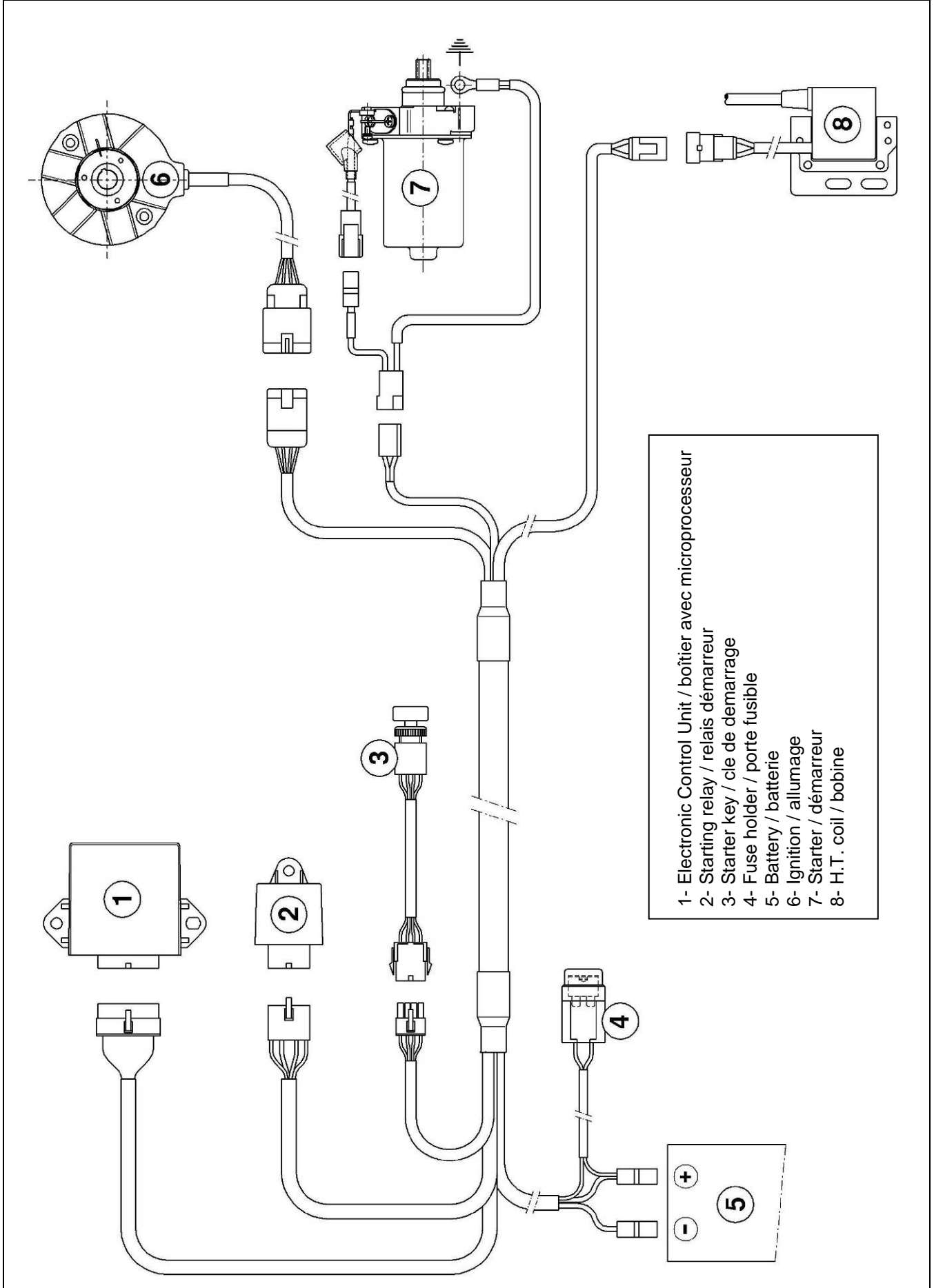

- 1- Electronic Control Unit / boîtier avec microprocesseur
- 2- Starting relay / relais démarrage
- 3- Starter key / cle de démarrage
- 4- Fuse holder / porte fusible
- 5- Battery / batterie
- 6- Ignition / allumage
- 7- Starter / démarrage
- 8- H.T. coil / bobine

ELECTRONIC BOX MARKING
MARQUAGE DU BOITIER ELECTRONIQUE

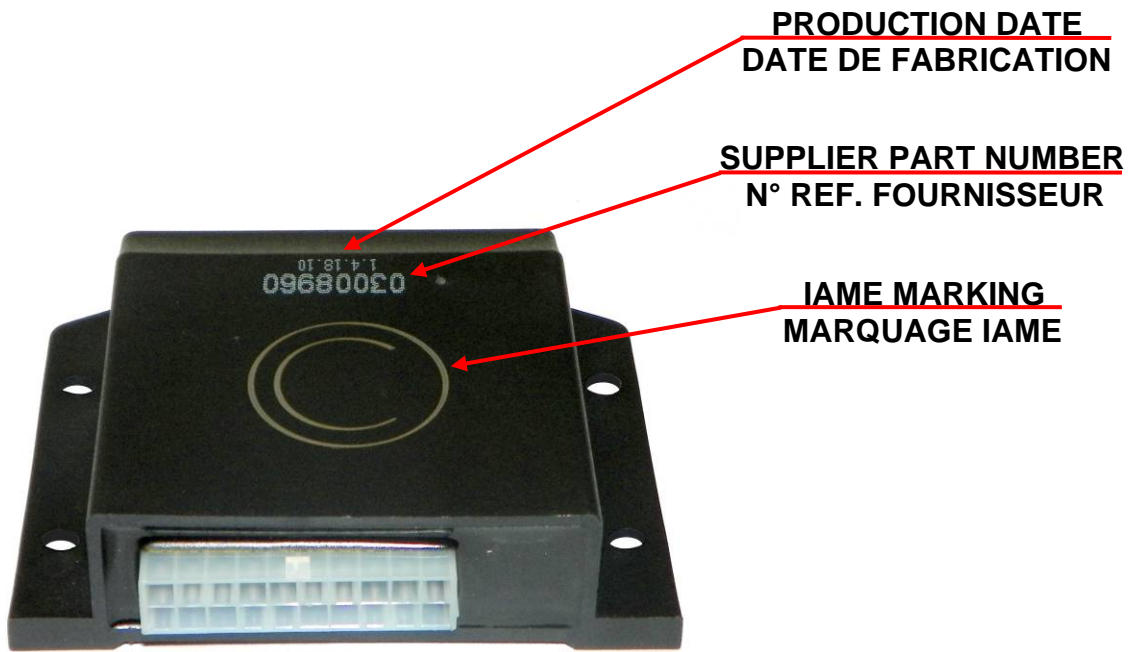

GEAR ALTERNATIVE FIXING
FIXATION ALTERNATIVE DE L' ENGRANAGE

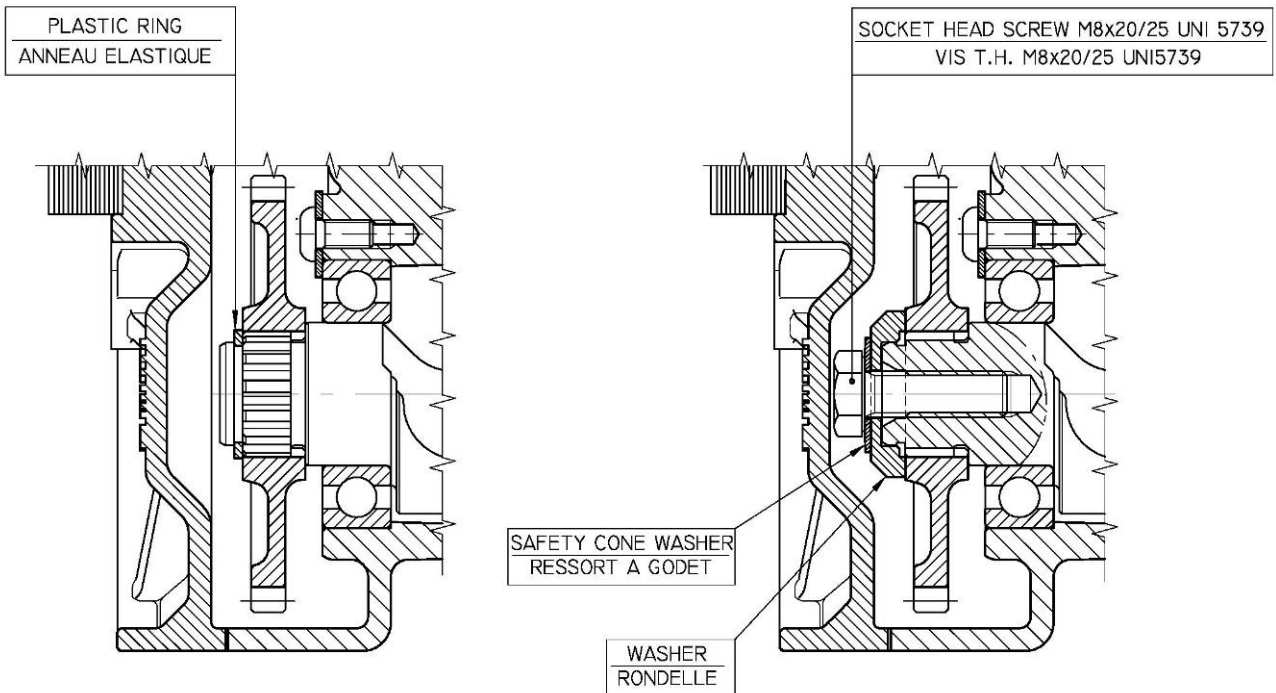

CARBURETTOR COVER ALTERNATIVE
ALTERNATIF COUVERCLE CARBURATEUR

EN PRODUCTION JUSQU' EN
SEPTEMBRE 2007

EN PRODUCTION A PARTIR
D' OCTOBRE 2007

IN PRODUCTION UNTIL
SEPTEMBER 2007

IN PRODUCTION STARTING
FROM OCTOBER 2007

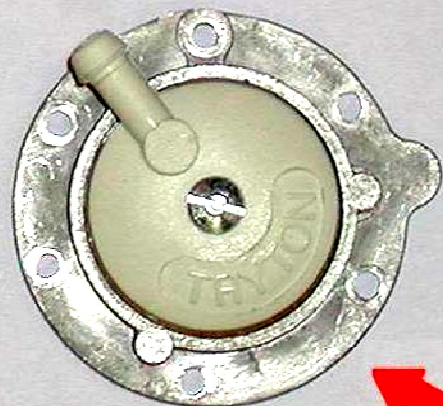
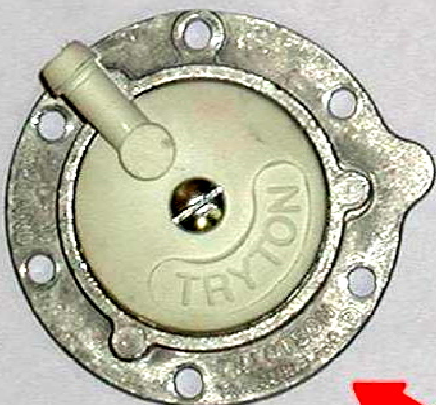
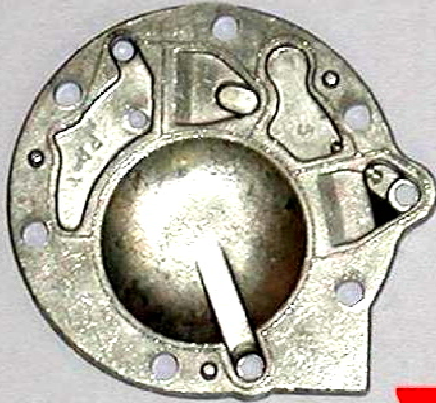

EN PRODUCTION JUSQU' EN
DECEMBRE 2008

EN PRODUCTION A PARTIR
DE JANVIER 2009

IN PRODUCTION UNTIL
DECEMBER 2008

IN PRODUCTION STARTING
FROM JANUARY 2009



DESCRIPTION OF THE CLUTCH - DESCRIPTION DE L' EMBRAYAGE

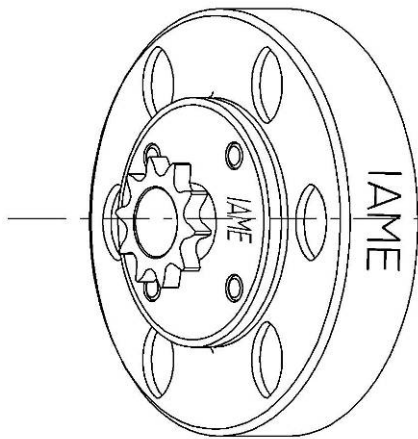

Min. weight 300 g
Poids min. 300 g

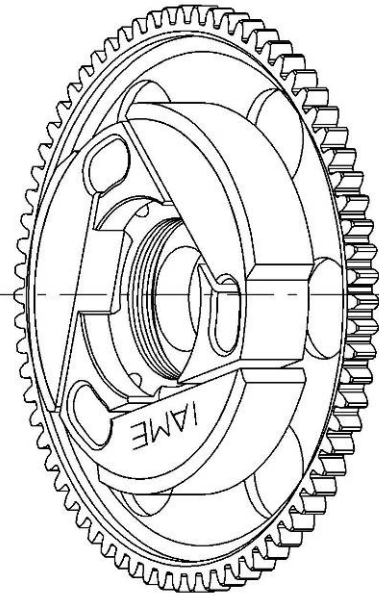

Min. weight 650 g
Poids min. 650 g

EXHAUST RESTRICTOR
REDUCTION D' ECHAPPEMENT

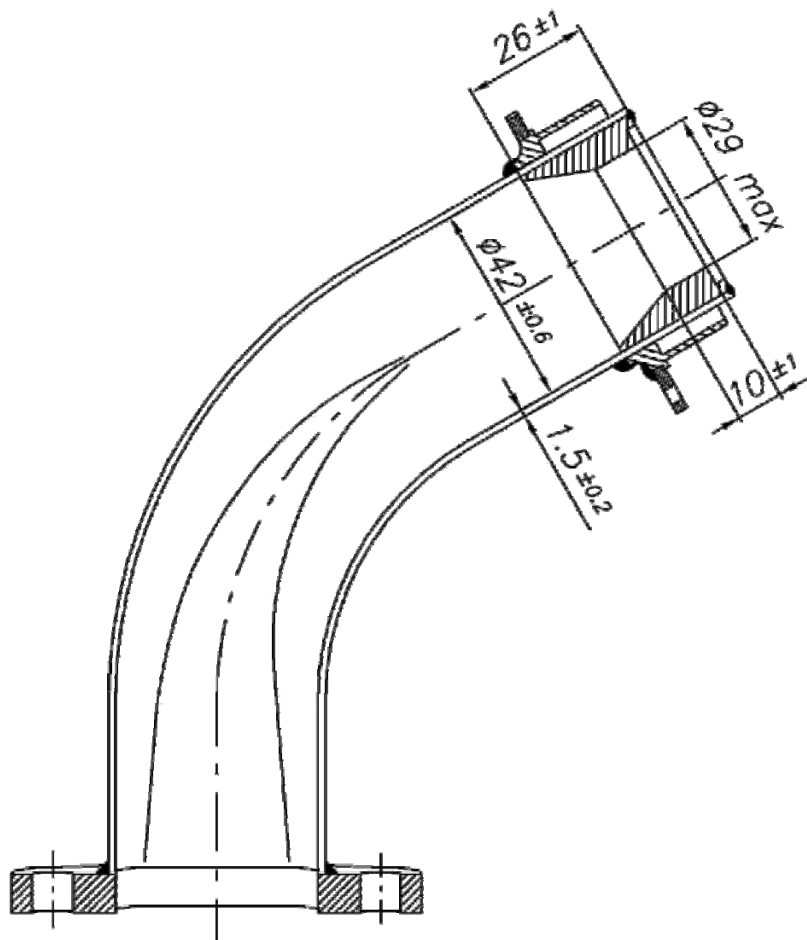

RADIATOR DESCRIPTION AND SKETCH OF PARTS
DESCRIPTION DU RADIATEUR ET SCHEMA ILLUSTRANT LES ELEMENTS

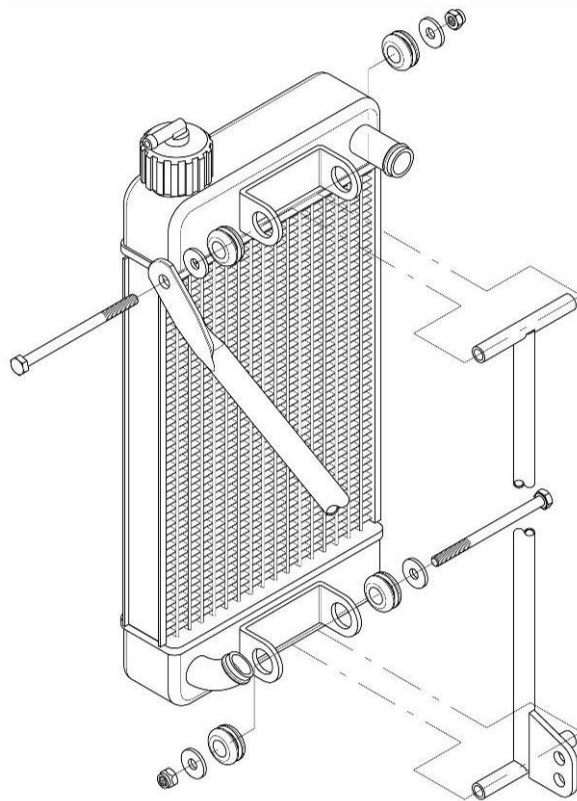
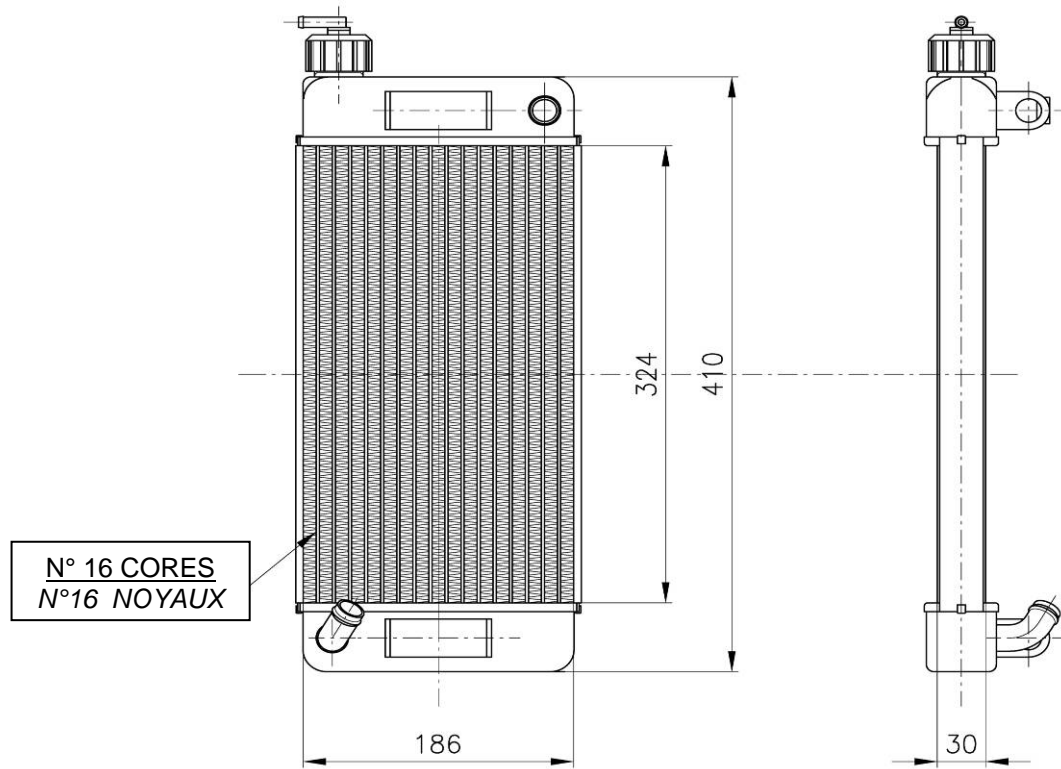

RADIATOR AND ITS SUPPORTS
 RADIATEUR ET SES SUI TIEN

PAINTED AND NOT PAINTED / PEINT ET PAS PEINT



FRONT / AVANT



REAR / ARRIERE



WATER PUMP GROUP
 GROUPE POMPE A' EAU

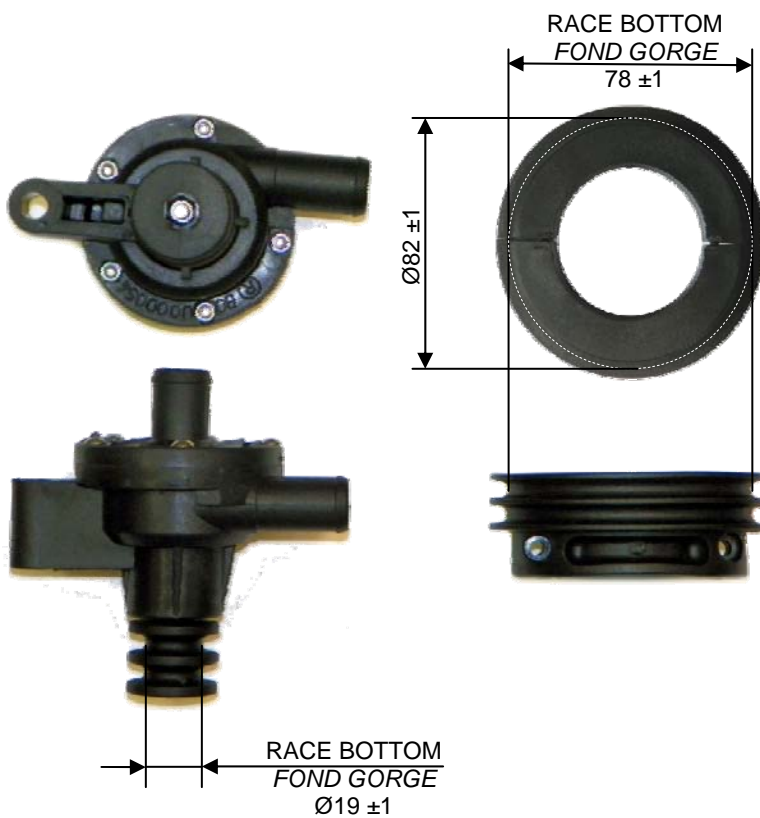

THERMOSTAT



ALTERNATIVE



PISTON IDENTIFICATION MARKING
 MARQUAGE D'IDENTIFICATION PISTON

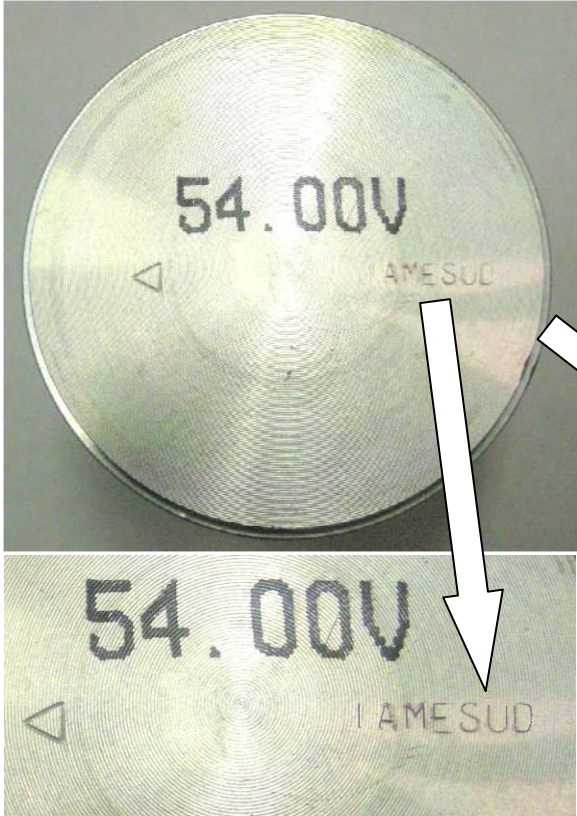
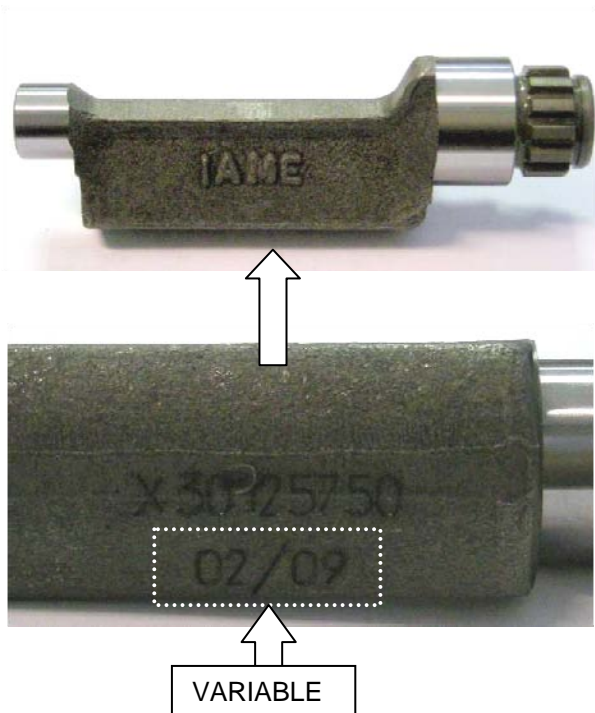
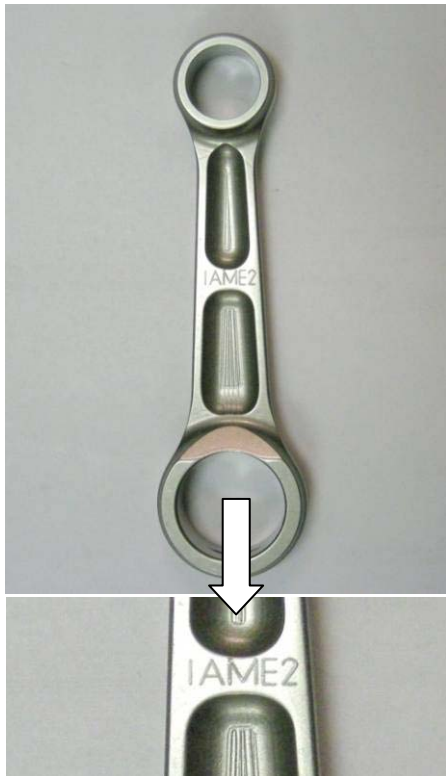
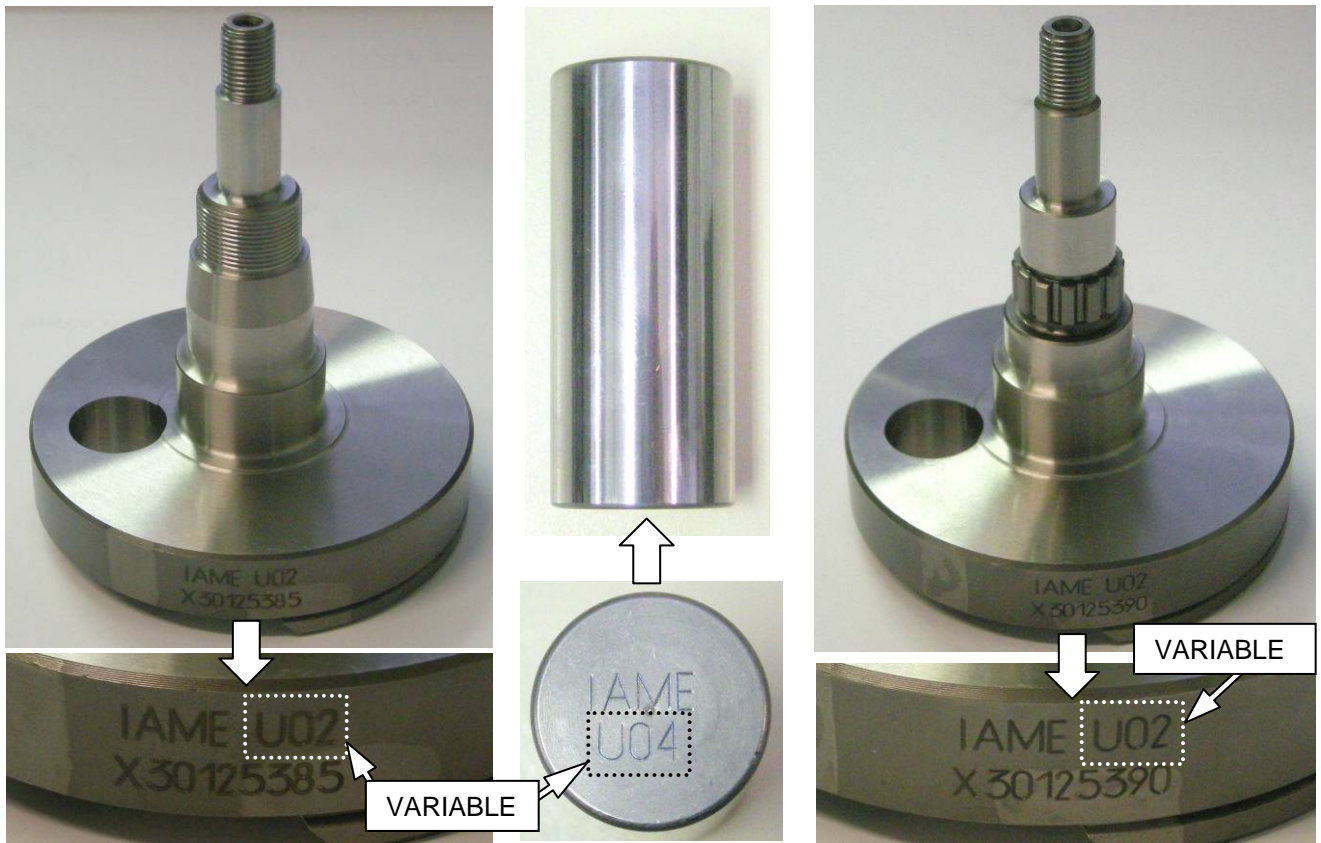

PHOTO IDENTIFICATION CONROD
 MARQUAGE D'IDENTIFICATION BIELLE

IDENTIFICATION BALANCING SHAFT
 MARKING
 MARQUAGE D'IDENTIFICATION ARBRE
 D'EQUILIBRAGE



CRANKSHAFT IDENTIFICATION MARKING
 MARQUAGE D'IDENTIFICATION DU VILEBREQUIN



GEAR COMMAND BALANCING SHAFT
 IDENTIFICATION MARKING
 MARQUAGE D'IDENTIFICATION
 ENGRENAGE ARBRE D'EQUILIBRAGE

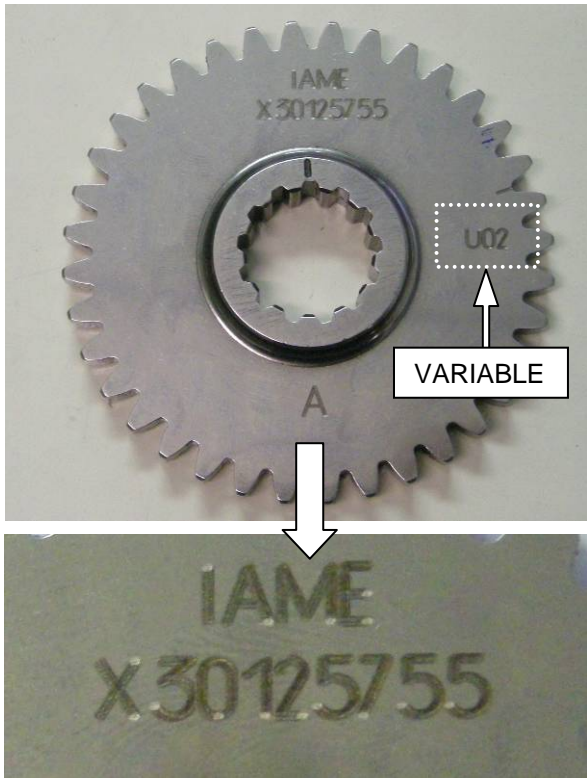

STARTER RING IDENTIFICATION MARKING
 MARQUAGE D'IDENTIFICATION DE LA
 COURONNE DE DEMARRAGE

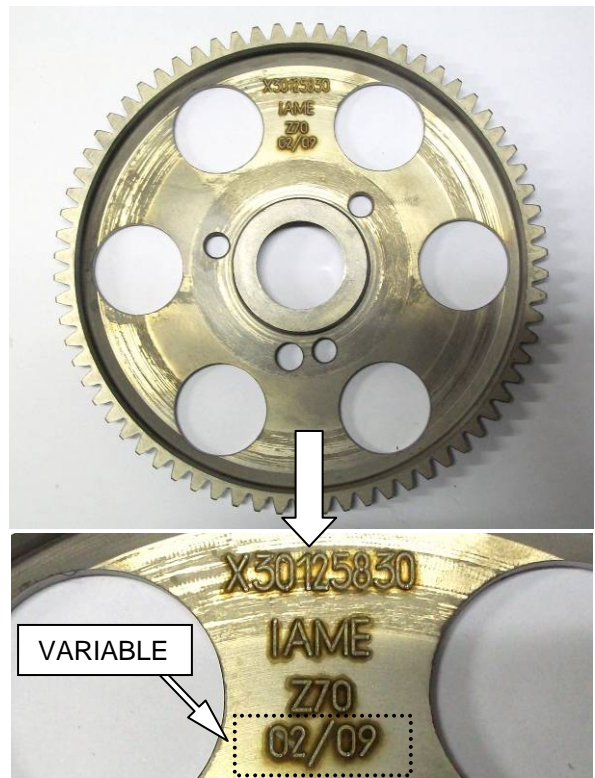

SPROCKET IDENTIFICATION MARKING
 MARQUAGE D'IDENTIFICATION DU
 PIGNON

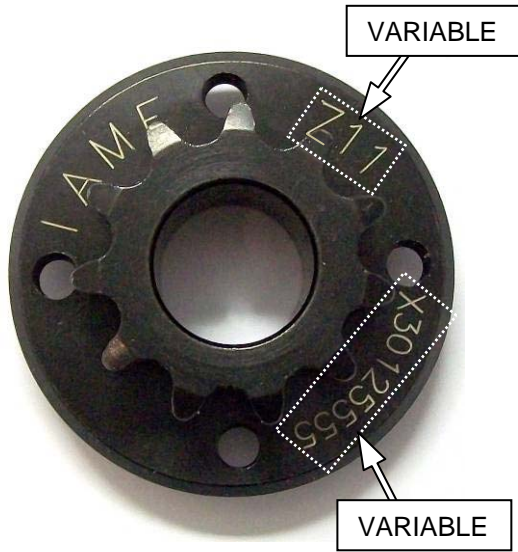

CLUTCH DRUM IDENTIFICATION MARKING
 MARQUAGE D'IDENTIFICATION DE LA
 CALOTTE



CLUTCH BODY IDENTIFICATION
 MARKING
 MARQUAGE D'IDENTIFICATION CORPS
 DE EMBRAYAGE

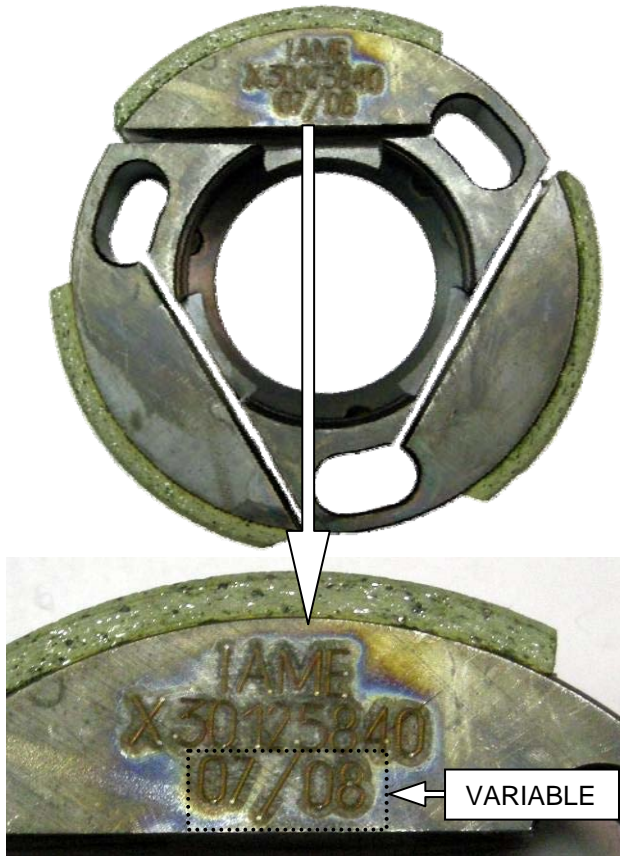

STARTER IDENTIFICATION MARKING
 MARQUAGE D'IDENTIFICATION DU
 MOTEUR DEMARREUR

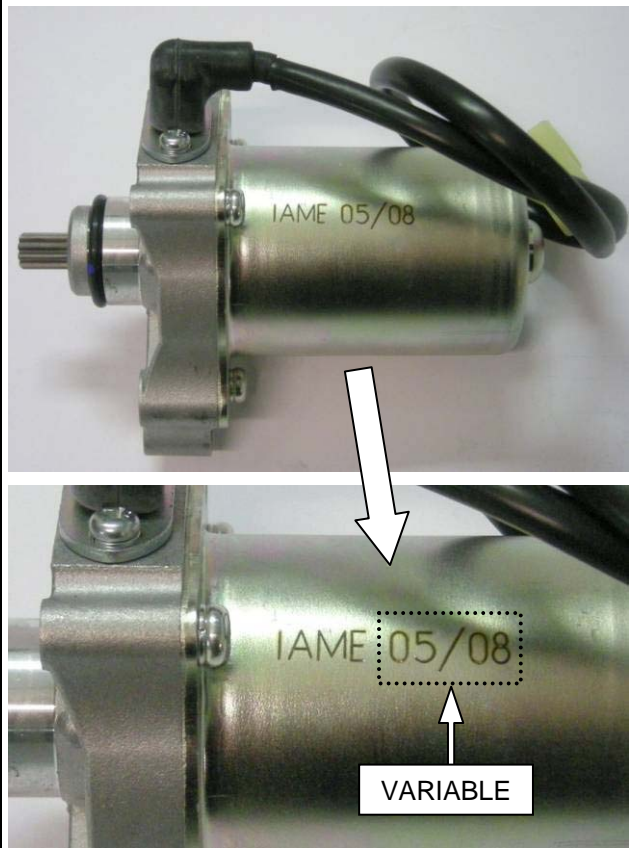

REED GROUP & PETALS IDENTIFICATION MARKING
 MARQUAGE D'IDENTIFICATION DE LA PYRAMIDE DE CLAPETS & CLAPETS

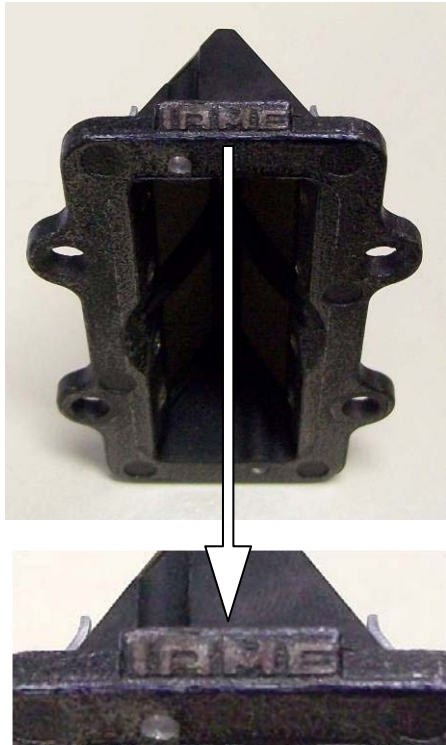
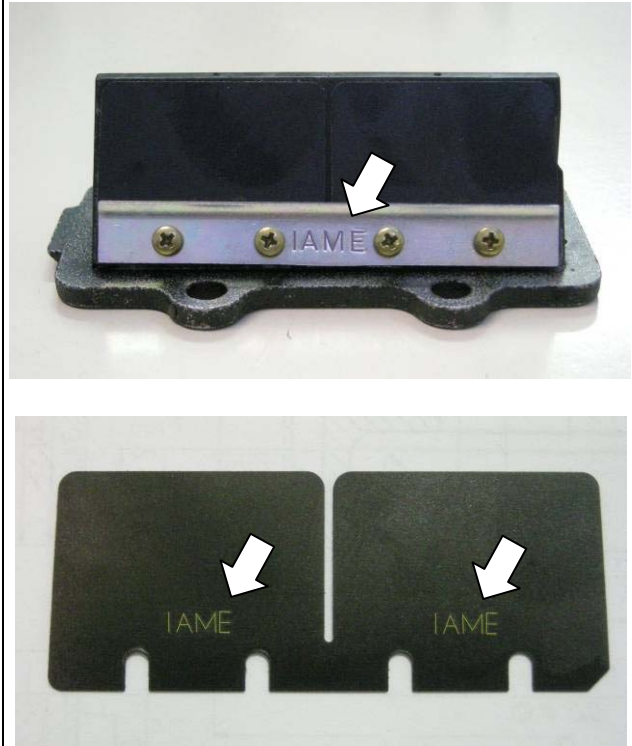

PHOTO IDENTIFICATION
 CARBURETOR INLET CONVEYOR
 MARQUAGE D'IDENTIFICATION DU
 COLLECTEUR D'ASPIRATION



EXHAUST SILENCER IDENTIFICATION
 MARKING
 MARQUAGE D'IDENTIFICATION
 ECHAPPEMENT



HEADER EXHAUST IDENTIFICATION MARKING
MARQUAGE DE LA COUDE D'ECHAPPEMENT



STATOR IDENTIFICATION MARKING
MARQUAGE D'IDENTIFICATION DU STATOR

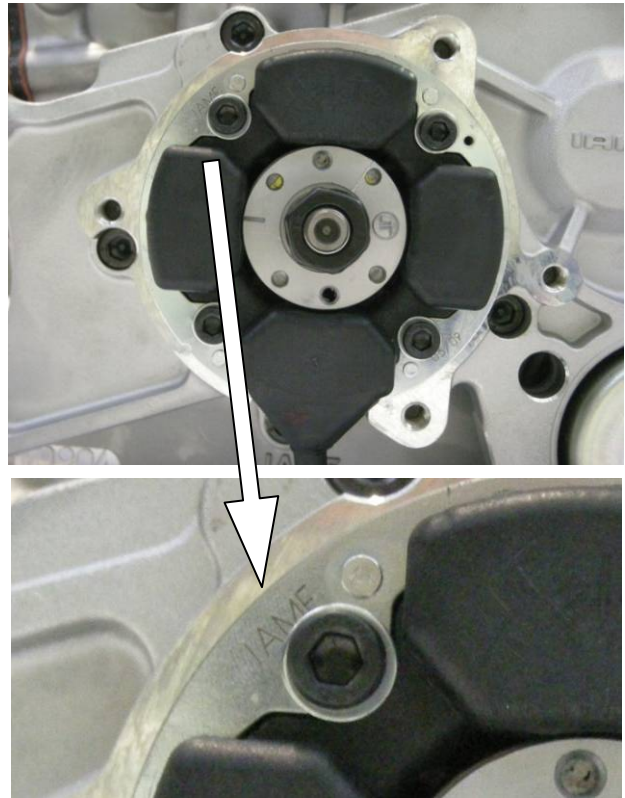

CLUTCH COVER AND H.T. COIL IDENTIFICATION MARKING
MARQUAGE DU COUVERCLE D'EMBAYAGE ET DE LA BOBINE

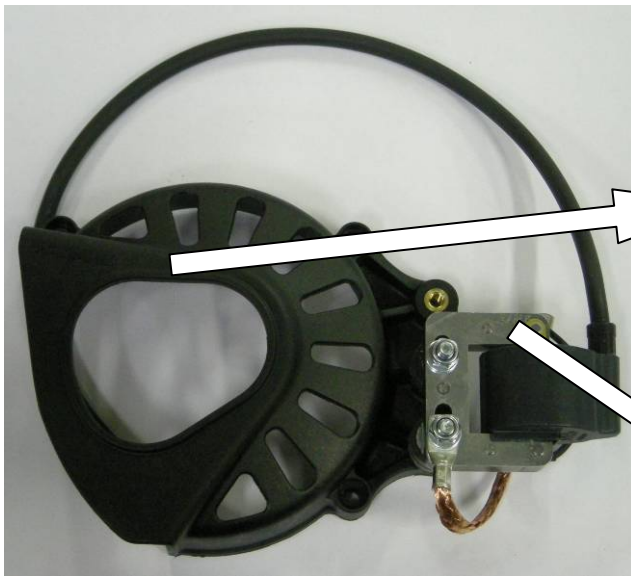

BENDIX COVER IDENTIFICATION MARKING
MARQUAGE D'IDENTIFICATION DU COUVERCLE DU COUNTER-ARBRE DE
DEMARRAGE

