



125cc RL - TaG

Agrement CK 2 en date du 13 décembre 2013

CARBURETTOR / CARBURATEUR TRYTON HOBBY 27-C / 2009



PHOTO OF INLET SIDE
PHOTO CÔTÉ ASPIRATION



PHOTO OF ADJUSTING SIDE
PHOTO CÔTÉ RÉGLAGE

Manufacturer <i>Constructeur</i>	VA.MEC SRL
Make <i>Marque</i>	TRYTON
Model <i>Modèle</i>	HOBBY 27-C

SECTION VIEW / VUE EN SECTION

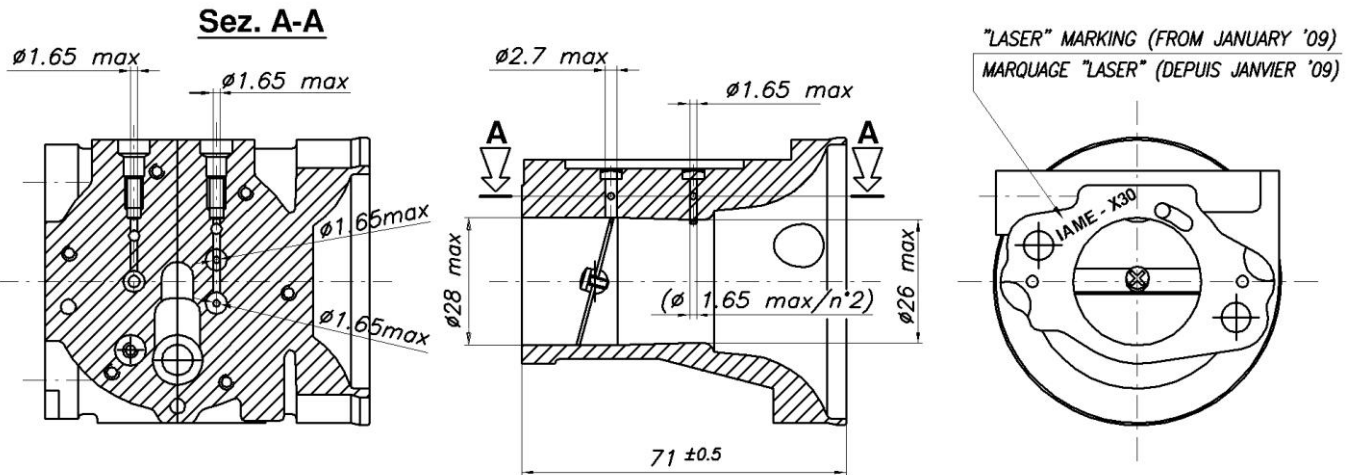

CARBURETTOR DESCRIPTION AND SKETCH OF PARTS
DESCRIPTION DU CARBURATEUR ET ESQUISSE DES PIÈCES

Rif.	DESCRIPTION	
1	COVER SCREW	VIS COUVERCLE
2	FILTER COVER	COUVERCLE FILTRE
3	COVER GASKET	JOINT COUVERCLE
4	FUEL SCREEN FILTER	FILTRE CARBURANT
5	BODY SCREW	VIS CORPS CARBURATEUR
6	VALVE BODY	CORPS VALVE
7	PUMP DIAPHRAGM	MEMBRANE POMPE
8	PUMP DIAPHRAGM GASKET	JOINT MEMBRANE POMPE
9	PUMP BODY	CORPS POMPE
10	DIAPHRAGM	MEMBRANE PRINCIPALE
11	DIAPHRAGM GASKET	JOINT MEMBRANE PRINCIP.
12	NEEDLE LOW SPEED	VIS REGLAGE MINIMUM
13	NEEDLE SPRING	RESSORT VIS REGLAGE
14	NEEDLE WASHER	RONDELLE VIS REGLAGE
15	NEEDLE O-RING	ANNEAU VIS REGLAGE
16	NEEDLE HIGH SPEED	VIS REGLAGE MAXIMUM
17	SCREW LEVER	VIS LEVIER
18	NEEDLE VALVE	POINTEAU COMPLET
19	LEVER PIN	AXE
20	INLET LEVER	LEVIER
21	INLET LEVER SPRING	RESSORT LEVIER
22	THROTTLE SHUTTER SCREW	VIS FIXATION PAPILLON
23	THROTTLE SHUTTER	PAPILLON CARBURATEUR
24	SHAFT RETAINING RING	ANNEAU AXE
25	BRACKET	ETRIER COMPLET
26	SHAFT SHUTTER	AXE COMPLET PAPILLON
27	SHAFT SPRING	RESSORT RENVOI AXE
28	BRACKET SCREW	VIS FIXATION ETRIER
29	PLUG	BOUCHON
30	BOLT	ECROU FIXATION CARBUR.

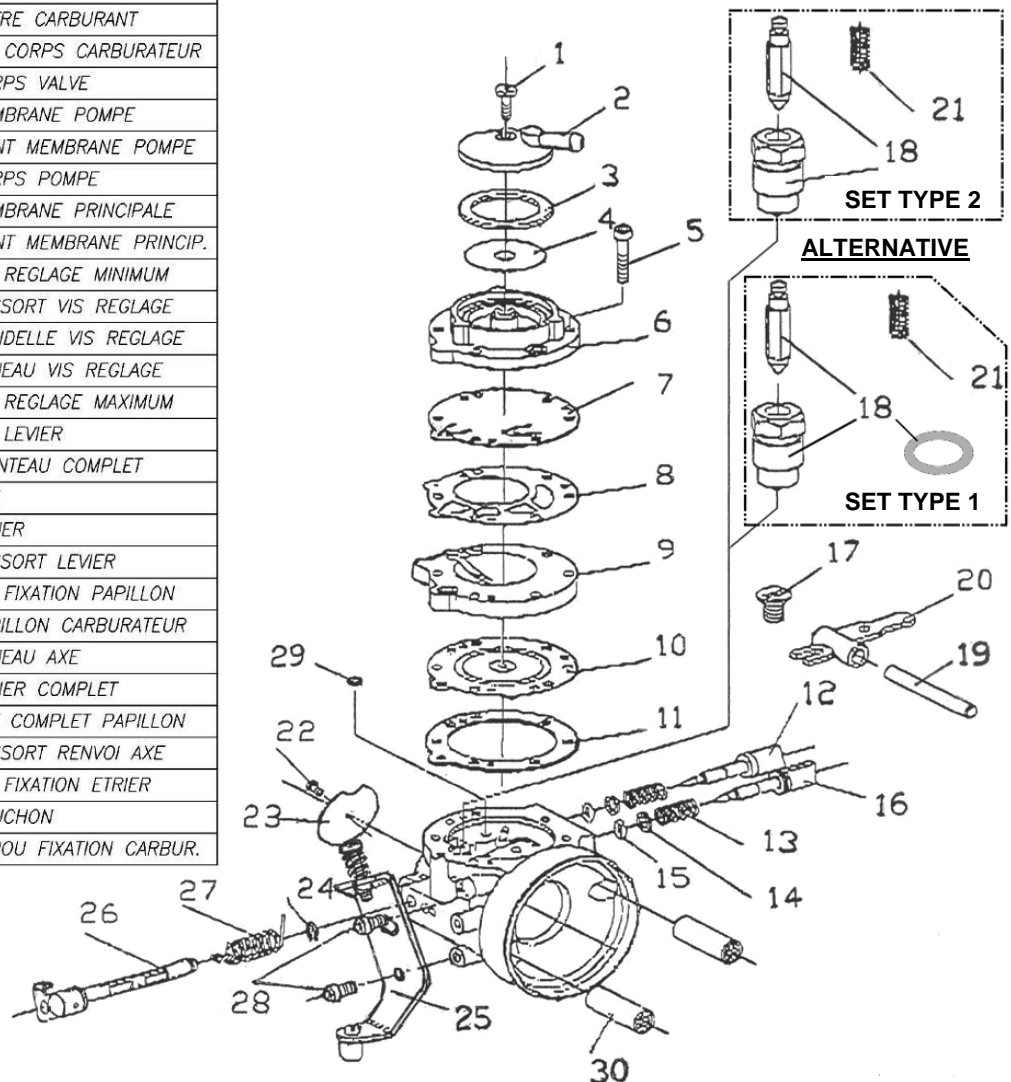

SET TYPE 1 – ACTUAL
 GROUPE TYPE 1 - COURANT

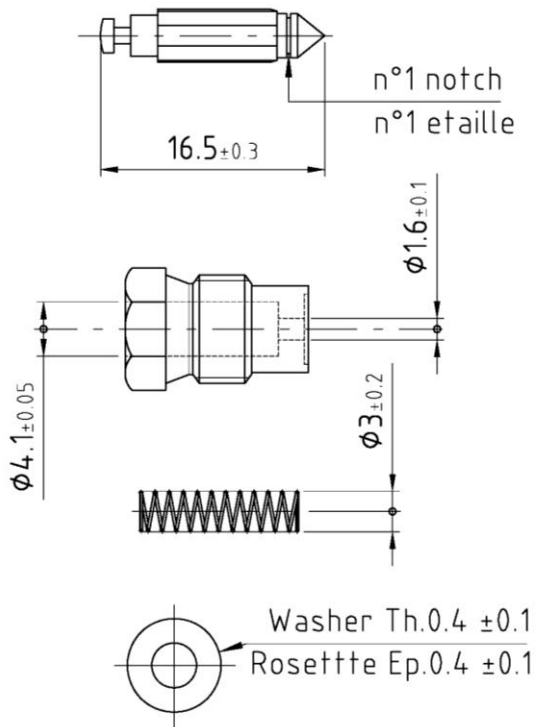

SET TYPE 2 – 2011
 GROUPE TYPE 2 - 2011

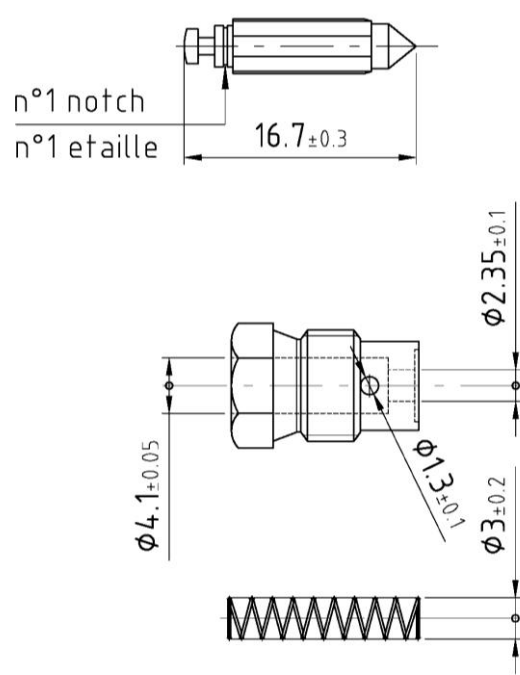
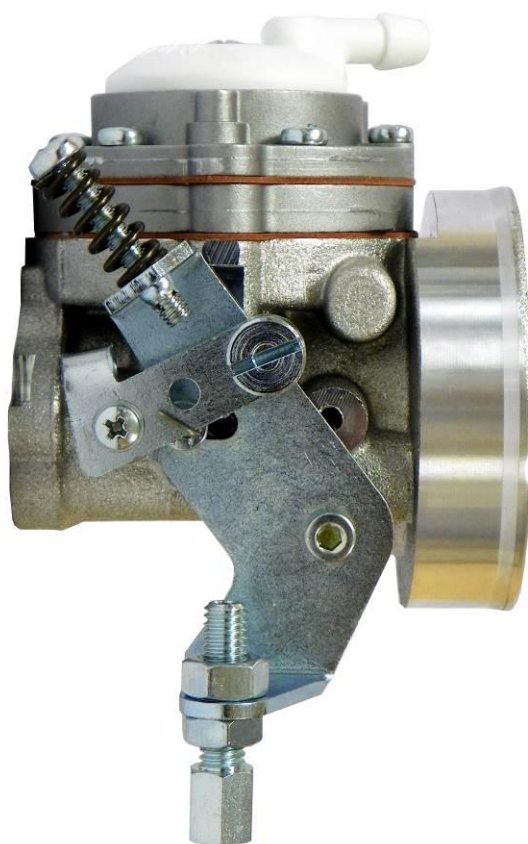

PHOTO IDENTIFICATION SET TYPE 1
 PHOTO D'IDENTIFICATION GROUPE TYPE 1

PHOTO IDENTIFICATION SET TYPE 2 – 2011
 PHOTO D'IDENTIFICATION GROUPE TYPE 2



BRACKET CABLE & LIMITER
ETRIER CABLE & GROUP LIMITEUR



IN ALTERNATIVE

