

FICHE D'HOMOLOGATION HOMOLOGATION FORM



COMMISSION INTERNATIONALE DE KARTING - FIA



SYSTÈME DE FREINAGE / BRAKING SYSTEM

Constructeur	<i>Manufacturer</i>	C.R.G.
Marque	<i>Make</i>	CRGSPA
Modèle	<i>Model</i>	BK-09
Catégorie	<i>Category</i>	2WP
Durée de l'homologation	<i>Validity of the homologation</i>	6 ans / years
Nombre de pages	<i>Number of pages</i>	4





La présente Fiche d'Homologation reproduit descriptions, illustrations et dimensions du système de freinage au moment de l'homologation CIK-FIA. Le Constructeur a la possibilité de les modifier, mais seulement dans les limites fixées par le Règlement CIK-FIA en vigueur.

This Homologation Form reproduces descriptions, illustrations and dimensions of the brake system at the moment of the CIK-FIA homologation. The Manufacturer may modify them, but only within the limits set by the CIK-FIA Regulations in force.

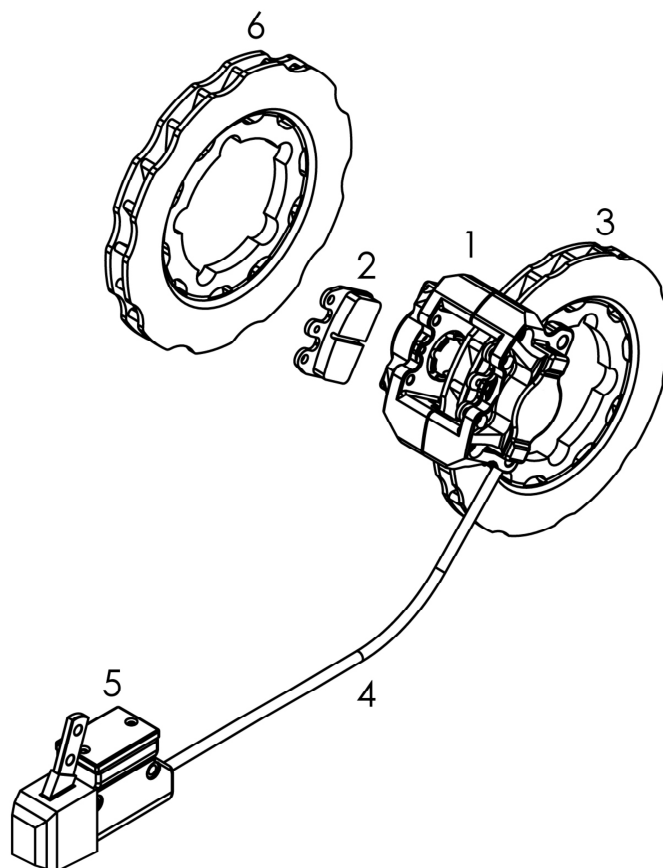

PHOTO VUE DE DESSUS DU SYSTÈME COMPLET ASSEMBLÉ

PHOTO FROM ABOVE OF COMPLETE ASSEMBLED SYSTEM

Signature et tampon de l'ASN <i>Signature and stamp of the ASN</i>	Signature et tampon de la CIK-FIA <i>Signature and stamp of the CIK-FIA</i>
 	  

A	DESSIN TECHNIQUE DU SYSTÈME DE FREINAGE Dessin technique éclaté	A	TECHNICAL DRAWING OF BRAKING SYSTEM Exploded technical drawing
---	--	---	---



Le dessin technique doit montrer : Maître-cylindre, régulateur, répartiteur, tuyaux, étriers, plaquettes et disques
(numérotation selon table ci-dessous)

The technical drawing must show the following: Master-cylinder, regulator, distributor, lines, calipers, pads and discs (with numbering according table below)

N°	DÉSIGNATION (en français)	DESIGNATION (in english)	Référence catalogue
			<i>Catalogue reference number</i>
1		REAR CALIPER	FM0.01800
2		REAR PAD	AFS.01745
3		REAR DISC 189	AFS.03281
4		REAR LINE	AFS.00240
5		MATER CYLINDER	FM0.00192
6		REAR DISC OPTIONAL 195	AFS.01727
7			
8			
9			
10			

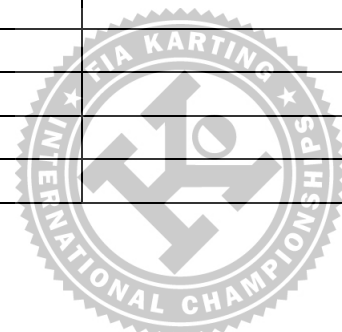

B	DESCRIPTION TECHNIQUE DU SYTÈME DE FREINAGE	B	TECHNICAL DESCRIPTION OF BRAKING SYSTEM	
	Régulateur de freinage <i>Braking regulator</i>	<input type="checkbox"/> oui / yes <input checked="" type="checkbox"/> non / no	Emplacement <i>Location</i>	
		Avant / Front	Arrière / Rear	
	Nombre de maîtres-cylindres <i>Number of master cylinders</i>		1	
	Alésage Ø <i>Bore Ø</i>		22 mm	
	Nombre de pistons <i>Number of pistons</i>	Par étrier <i>Per caliper</i>	2	Par étrier <i>Per caliper</i>
	Alésage Ø de l'étrier <i>Caliper bore Ø</i>		30 mm	
	Nombre de plaquettes <i>Number of pads</i>	Par étrier <i>Per caliper</i>	2	Par étrier <i>Per caliper</i>
	Nombre d'étriers <i>Number of calipers</i>	Par roue <i>Per wheel</i>	1	
	Matériau des étriers <i>Caliper material</i>		ALUMINIUM	
	Disques ventilés <i>Ventilated discs</i>	<input type="checkbox"/> oui / yes <input type="checkbox"/> non / no	<input checked="" type="checkbox"/> oui / yes <input type="checkbox"/> non / no	
	Épaisseur du disque neuf <i>Thickness of new disc</i>	+/- 1 mm	18,0/18,5 mm	+/- 1 mm
	Ø extérieur du disque <i>External Ø of the disc</i>	+/- 1.5 mm	189/195 mm	+/- 1.5 mm
	Ø extérieur de frottement des plaquettes <i>External Ø of pads rubbing surface</i>	+/- 1.5 mm	188/194 mm	+/- 1.5 mm
	Ø intérieur de frottement des plaquettes <i>Internal Ø of pads rubbing surface</i>	+/- 1.5 mm	130/136 mm	+/- 1.5 mm
	Longueur hors-tout des plaquettes <i>Overall length of the pads</i>	+/- 1.5 mm	58 mm	+/- 1.5 mm
	Photo du frein avant : étriers et disques seulement <i>Photo of front brake: calipers and discs only</i>			
		 <p style="text-align: center;">Photo du frein arrière : étrier(s) et disque(s) seulement <i>Photo of rear brake: caliper(s) and disc(s) only</i></p>		

PHOTO DU MARQUAGE DU NUMERO D'HOMOLOGATION
PHOTO OF THE HOMOLOGATION NUMBER MARKING

Le marquage doit rester clairement visible en permanence
The marking must be clearly visible at all times

Maître-cylindre / Master-cylinder



Tuyaux / Lines

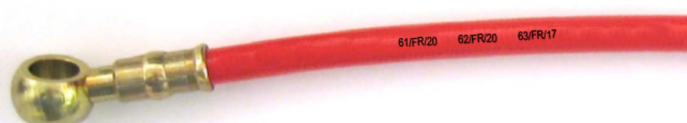

Etriers / Calipers



Plaquettes / Pads



Disques / Discs

Répartiteur / Distributor and/or Régulateur / Regulator