

# FICHE D'HOMOLOGATION / HOMOLOGATION FORM

033-B2-99



## COMMISSION INTERNATIONALE DE KARTING - FIA



### SYSTÈME DE FREINAGE / BRAKING SYSTEM 2 WP

Constructeur / <i>Manufacturer</i>	LENZOKART s.r.l.
Marque / <i>Make</i>	<b>LENZOKART</b>
Modèle / <i>Model</i>	<b>LKF12</b>
Catégorie / <i>Categorie</i>	Group 3
Durée de l'homologation / <i>Validity of the Homologation</i>	4 ans / 4 years
Nombre de pages / <i>Number of pages</i>	4
La présente Fiche d'Homologation reproduit descriptions, illustrations et dimensions du système de freinage au moment de l'homologation CIK-FIA.	<i>This Homologation Form reproduces descriptions, illustrations and dimensions of the brake system at the moment of the CIK-FIA homologation.</i>

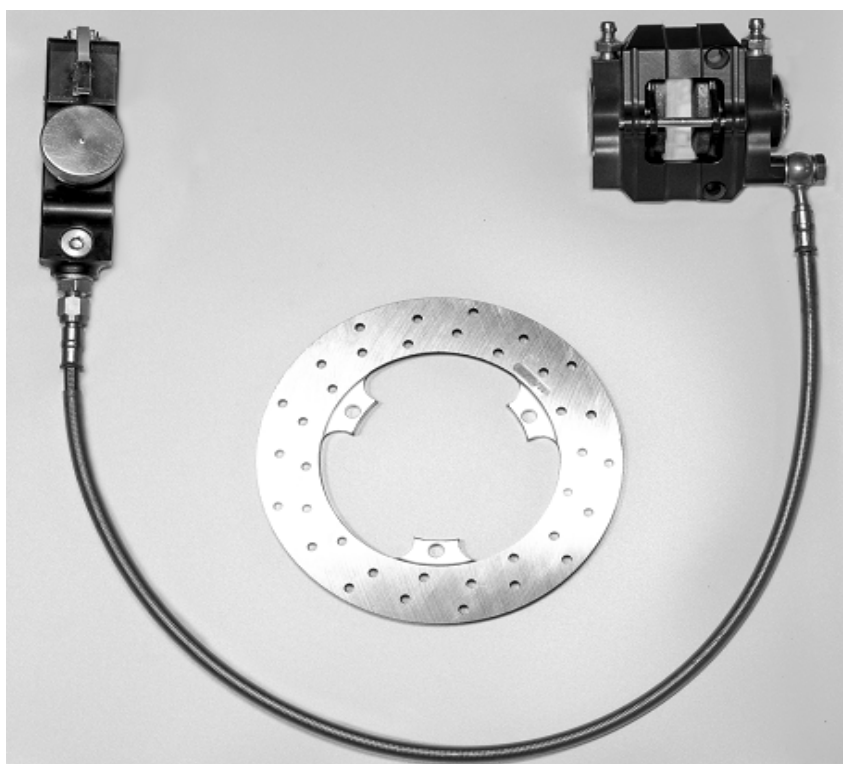
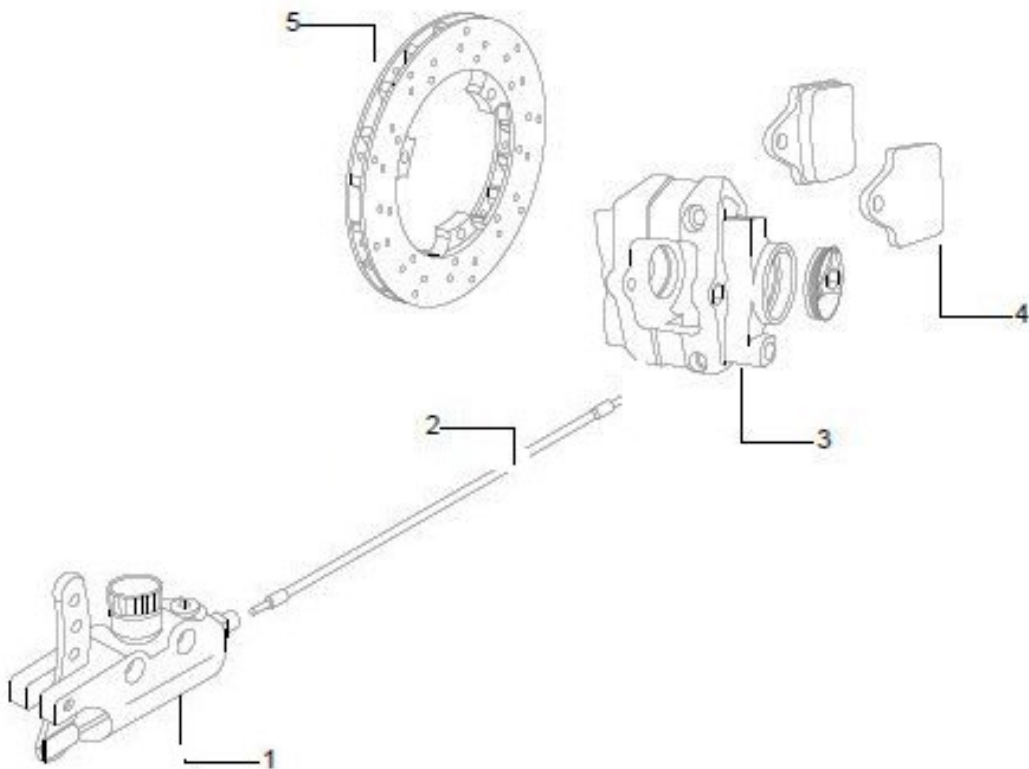

Photo vue de dessus du système complet / *Photo from above of complete system*

Signature et tampon de l'ASN / <i>Signature and stamp of the ASN</i>	Signature et tampon de la CIK-FIA / <i>Signature and stamp of the CIK-FIA</i>

A

**Dessin technique / Technical drawing**  
Dessin technique explosé / Exploded technical drawing



Le dessin technique doit montrer les éléments ci-après : maître-cylindre, régulateur, répartiteur, tuyaux, étriers, plaquettes et disques (numérotation selon tableau ci-dessous) /

*The technical drawing must show the following: Master cylinder, regulator, distributor, tubes, callipers, pads and discs (with numbering according to the table below)*

N°	Désignation / Designation	Référence catalogue Catalogue reference
1	Maitre-cylindre / Master cylinder	LK030A 6
2	Tuyau / Tube	LK030D LKF12
3	Etrier frein arriere / Rear brake caliper	LK033A LKF12
4	Plaquette frein arriere / Rear brake pad	LK032J LKF12
5	Disque frein arriere / Rear brake disc	LK034A LKF12

<b>B</b>	<b>Description technique / Technical description</b>		
	Nombre de maître-cylindres / <i>Number of master cylinders</i>	1	
	Alésage Ø / <i>Bore Ø</i>	19,5 mm	
	Nombre de pistons / <i>Number of pistons</i>	1	par étrier / <i>per caliper</i>
	Alésage Ø de l'étrier / <i>Caliper bore Ø</i>	26,55 mm	
	Nombre de plaquettes / <i>Number of pads</i>	2	par étrier / <i>per caliper</i>
	Nombre d'étriers / <i>Number of calipers</i>	1	
	Matériau des étriers / <i>Caliper material</i>	Alu	
	Disque ventilé / <i>Ventilated disc</i>	Oui / <i>Yes</i>	
	Épaisseur de disque neuf / <i>Thickness of new disc</i>	12 mm	± 1 mm
	Ø extérieur du disque / <i>External Ø of the disc</i>	155,5 mm	± 1.5 mm
	Longueur hors-tout des plaquettes / <i>Overall length of the pads</i>	39 mm	± 1.5 mm
	Longueur de matériel friction / <i>Length of the friction material</i>	37,5 mm	± 1.5 mm
	Hauteur de matériel friction / <i>Height of the friction material</i>	26,5 mm	± 1.5 mm

<b>C</b>	<b>Photo du frein arrière / Photo of rear brake</b>		
			
Étrier et disque seulement / <i>Caliper and disc only</i>			

D	Photo du marquage du numero d'homologation / Photo of the homologation number marking	
	Maitre-cylindre / Master-cylinder	Tuyau / Line
		
	Etrier / Caliper	Plaquettes / Pads
		
Disques / Discs		
		
Le marquage doit rester clairement visible en permanence / <i>The marking must be clearly visible at all times</i>		