

**FICHE D'HOMOLOGATION  
HOMOLOGATION FORM**

Homologation N°

**101/CA/20**



**COMMISSION INTERNATIONALE  
DE KARTING – FIA**



**CARENAGE AVANT / FRONT FAIRING**

Constructeur	<i>Manufacturer</i>	PAROLIN RACING KART SRL
Marque	<i>Make</i>	EUROSTAR
Modèle	<i>Model</i>	WINGS
Catégorie	<i>Category</i>	Toutes / All
Durée de l'homologation	<i>Validity of the homologation</i>	6 ans / years
Nombre de pages	<i>Number of pages</i>	3



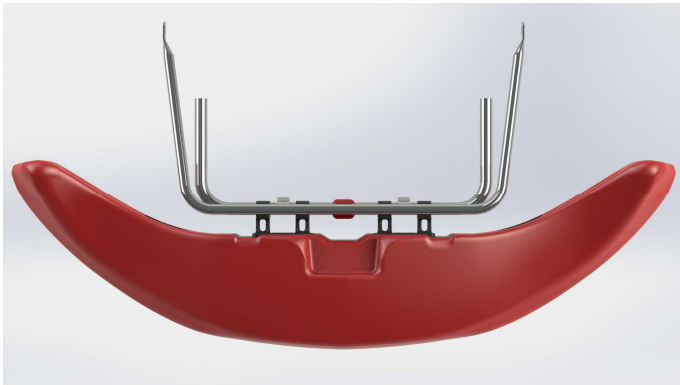

La présente Fiche d'Homologation reproduit descriptions, illustrations et dimensions au moment de l'homologation CIK-FIA.

*This Homologation Form reproduces descriptions, illustrations and dimensions at the moment of the CIK-FIA homologation.*



PHOTOS VUE DE DEVANT, DE DESSUS ET DE COTÉ, DU CARENAGE AVANT AVEC SUPPORTS

*PHOTO FROM FRONT, ABOVE AND SIDE OF FRONT FAIRING WITH SUPPORTS*

Signature et tampon de l'ASN <i>Signature and stamp of the ASN</i>	Signature et tampon de la CIK-FIA <i>Signature and stamp of the CIK-FIA</i>
 	 

**CARÉPAGE AVANT AVEC SUPPORTS**

Dessin technique (dimensions d'encombrement – matériau, diamètre et épaisseur des tubes supports)

**FRONT FAIRING WITH SUPPORTS**

Technical drawing (fairing main external dimensions – supports material, diameter and wall thickness)

Masse en g (carrosserie droite ou gauche seule)	Mass in g (RH or LH bodywork only)	1200 g	+/-10 %
Masse en g (support droit ou gauche seul)	Mass in g (RH or LH support only)	815 g	+/-5 %

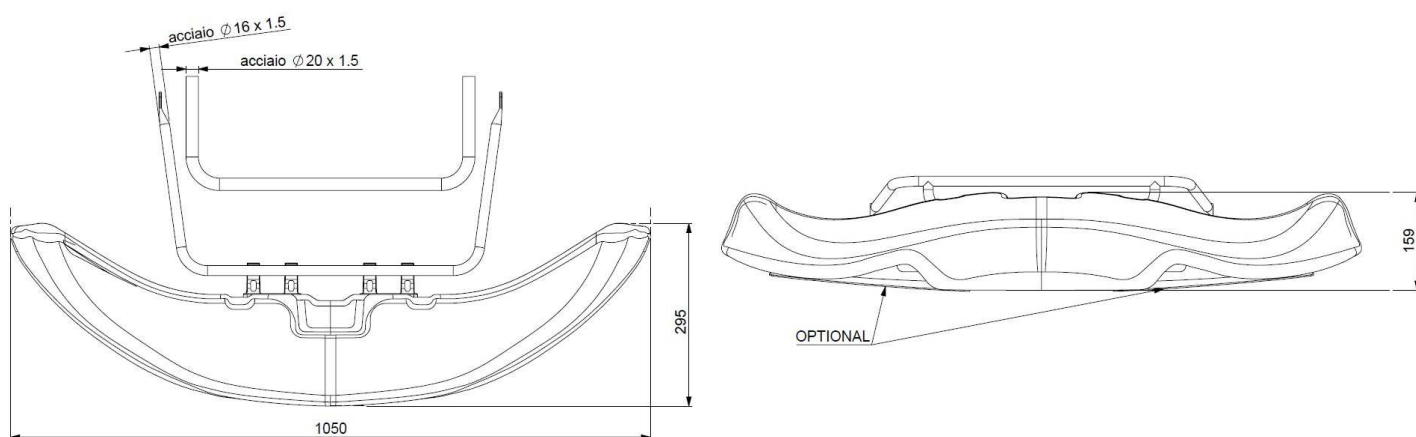

PHOTO (complet avec supports) / (complete with supports)



**FIXATION CARÉNAGE AVANT**

Dessin technique éclaté

**FRONT FAIRING ATTACHMENT***Exploded technical drawing*

PHOTO DU MARQUAGE DU NUMERO  
D'HOMOLOGATION (et du logo CIK-FIA sur les  
éléments plastiques)

PHOTO OF THE HOMOLOGATION NUMBER  
MARKING (and of the CIK-FIA logo on the  
plastic parts)



**Le marquage doit rester clairement visible en permanence**  
**The marking must be clearly visible at all times**

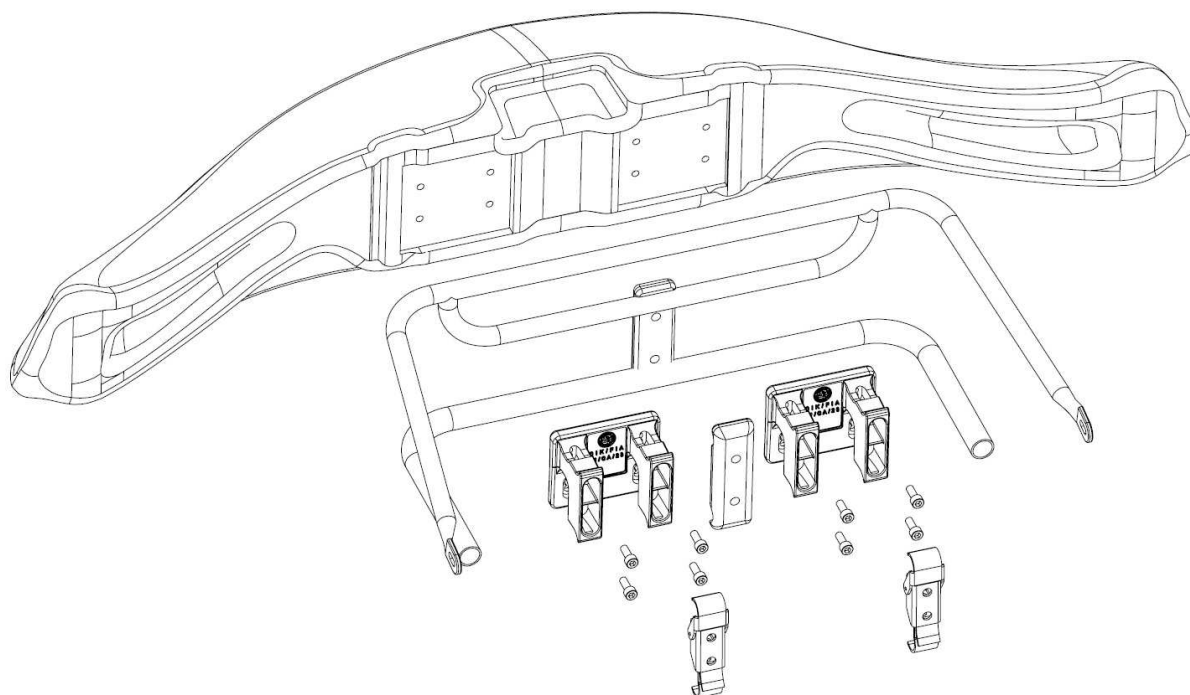