

FICHE D'HOMOLOGATION HOMOLOGATION FORM



COMMISSION INTERNATIONALE
DE KARTING – FIA



CARBURATEUR / CARBURETTOR

Constructeur	<i>Manufacturer</i>	ALEX BOLLHALDER
Marque	<i>Make</i>	BOLEX
Modèle	<i>Model</i>	B1
Catégorie	<i>Category</i>	KF2
Durée de l'homologation	<i>Validity of the homologation</i>	9 ans / 9 years
Nombre de pages	<i>Number of pages</i>	2

La présente Fiche d'Homologation reproduit descriptions, illustrations et dimensions du carburateur au moment de l'homologation CIK-FIA. Le Constructeur a la possibilité de les modifier seulement dans les limites fixées par le règlement CIK-FIA en vigueur.

This Homologation Form reproduces descriptions, illustrations and dimensions of the carburettor at the moment of the CIK-FIA homologation. The Manufacturer may modify them, but only within the limits fixed by the CIK-FIA regulations in force.



PHOTO CÔTÉ ASPIRATION
PHOTO OF INLET SIDE



PHOTO CÔTÉ RÉGLAGE
PHOTO OF ADJUSTING SIDE

Signature et tampon de l'ASN
Signature and stamp of the ASN

Signature et tampon de la CIK-FIA
Signature and stamp of the CIK-FIA

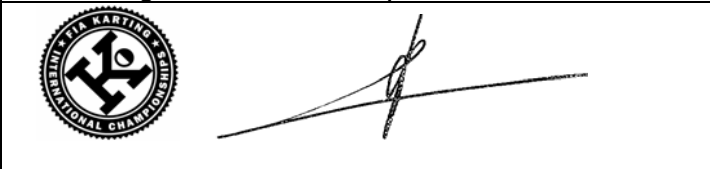
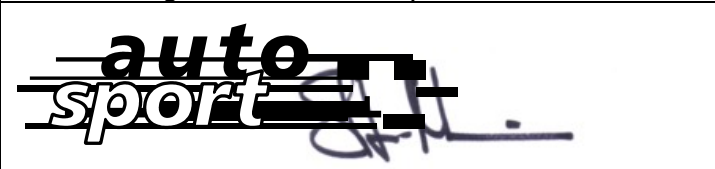

VUE EN SECTION
CONDUIT D'ASPIRATION
INLET PORT SECTION VIEW

VUE DE FACE
CÔTÉ ASPIRATION
INLET SIDE FRONT VIEW

Echelle 1:1 / 1:1 Scale

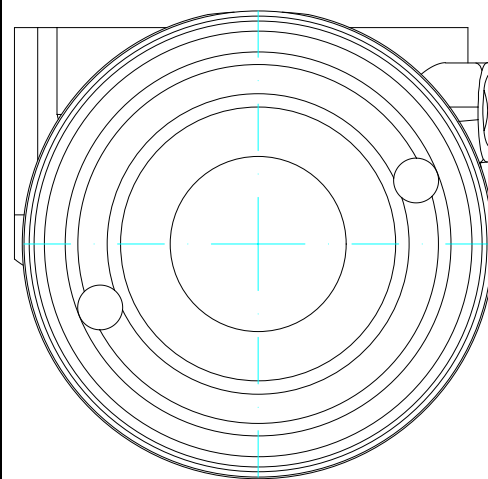
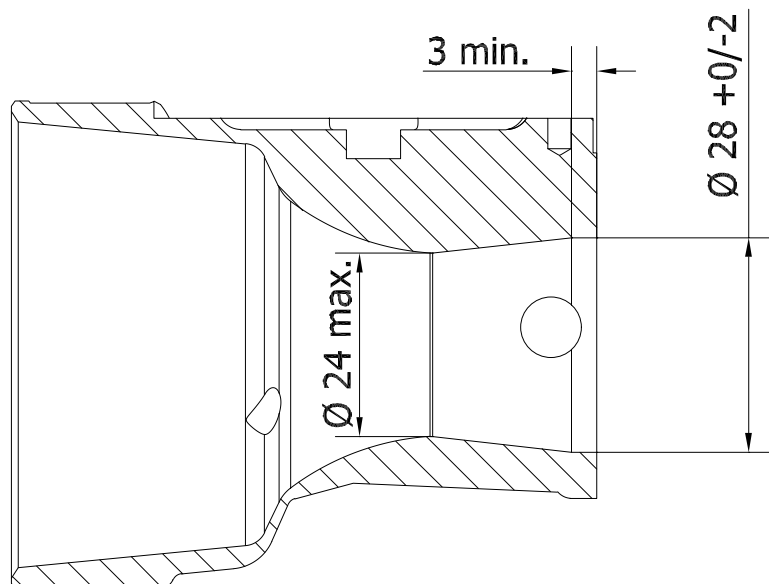

DESCRIPTION DU CARBURATEUR ET
ESQUISSE DES PIÈCES

CARBURETTOR DESCRIPTION AND
SKETCH OF PARTS

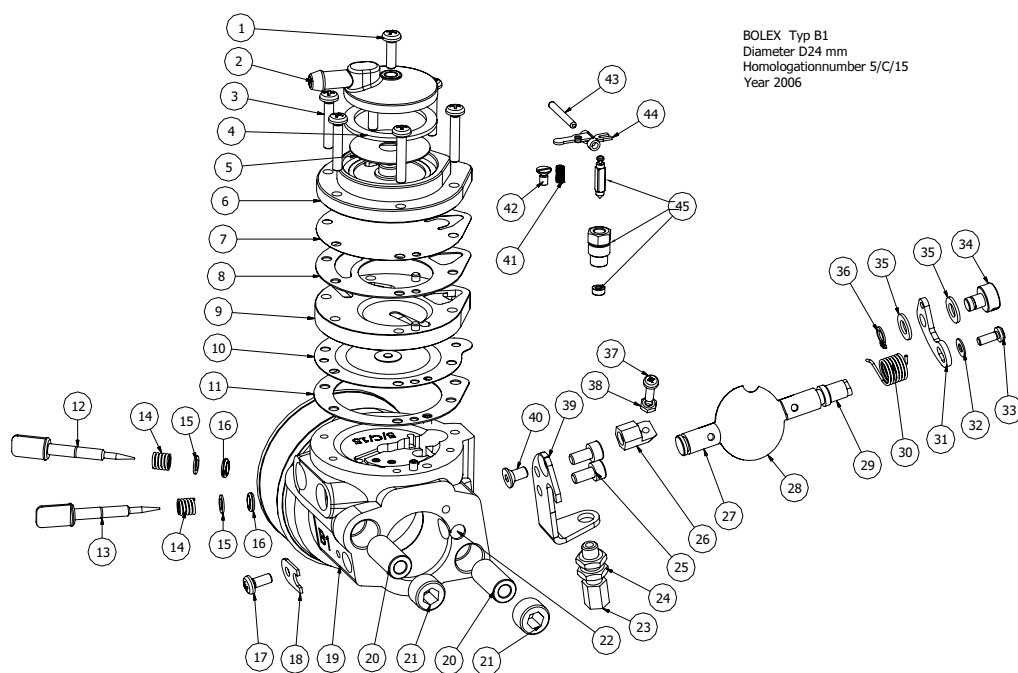

BOLEX Typ B1
Diameter D24 mm
Homologationnumber 5/C/15
Year 2006

- Pos. 1 Fuel Strainer Cover screw
- Pos. 2 Fuel Strainer Cover
- Pos. 3 Fuel Pump Screw (6)
- Pos. 4 Fuel Strainer Gasket
- Pos. 5 Fuel Strainer Screen
- Pos. 6 Fuel Pump Body
- Pos. 7 Fuel Pump Diaphragm
- Pos. 8 Fuel Pump Gasket
- Pos. 9 Diaphragm Cover
- Pos. 10 Metering-Diaphragm
- Pos. 11 Metering-Diaphragm Gasket
- Pos. 12 High Speed Mixture screw
- Pos. 13 Low Speed Mixture screw
- Pos. 14 Idle Mixture Spring (2)
- Pos. 15 Idle Mixture screw Washer (2)
- Pos. 16 Idle Mixture screw Packing (2)
- Pos. 17 Retaining screw
- Pos. 18 Throttle Shaft clip
- Pos. 19 Carburettor Body
- Pos. 20 Fixation Nut
- Pos. 21 Fastening Nut
- Pos. 22 Cap
- Pos. 23 Cable Adjusting screw
- Pos. 24 Nut M6 (2)
- Pos. 25 Screw M4x8 (2)
- Pos. 26 Stop Screw Holder
- Pos. 27 Shaft short
- Pos. 28 Throttle Shutter
- Pos. 29 Shaft long
- Pos. 30 Shaft Spring
- Pos. 31 Shaft lever
- Pos. 32 Lockwasher
- Pos. 33 Screw M3.5x8
- Pos. 34 Cable holder
- Pos. 35 Washer M5
- Pos. 36 Washer Holder Clip
- Pos. 37 Stop screw M3x12
- Pos. 38 Nut M3
- Pos. 39 Bracket
- Pos. 40 Screw M4x8
- Pos. 41 Inlet Tension Spring
- Pos. 42 Inlet Control Lever Fulcrum Screw
- Pos. 43 Inlet Control Lever Fulcrum Pin
- Pos. 44 Inlet Control Lever
- Pos. 45 Inlet Needle Seat and Gasket