

# FICHE D'HOMOLOGATION HOMOLOGATION FORM



COMMISSION INTERNATIONALE  
DE KARTING – FIA



## CARBURATEUR / CARBURETTOR

Constructeur	<i>Manufacturer</i>	<b>IBEA CARBURETTOR (CH)</b>
Marque	<i>Make</i>	<b>IBEA</b>
Modèle	<i>Model</i>	<b>L7</b>
Catégorie	<i>Category</i>	<b>KF1</b>
Durée de l'homologation	<i>Validity of the homologation</i>	9 ans / 9 years
Nombre de pages	<i>Number of pages</i>	2

La présente Fiche d'Homologation reproduit descriptions, illustrations et dimensions du carburateur au moment de l'homologation CIK-FIA. Le Constructeur a la possibilité de les modifier seulement dans les limites fixées par le règlement CIK-FIA en vigueur.

This Homologation Form reproduces descriptions, illustrations and dimensions of the carburettor at the moment of the CIK-FIA homologation. The Manufacturer may modify them, but only within the limits fixed by the CIK-FIA regulations in force.



PHOTO CÔTÉ ASPIRATION  
PHOTO OF INLET SIDE

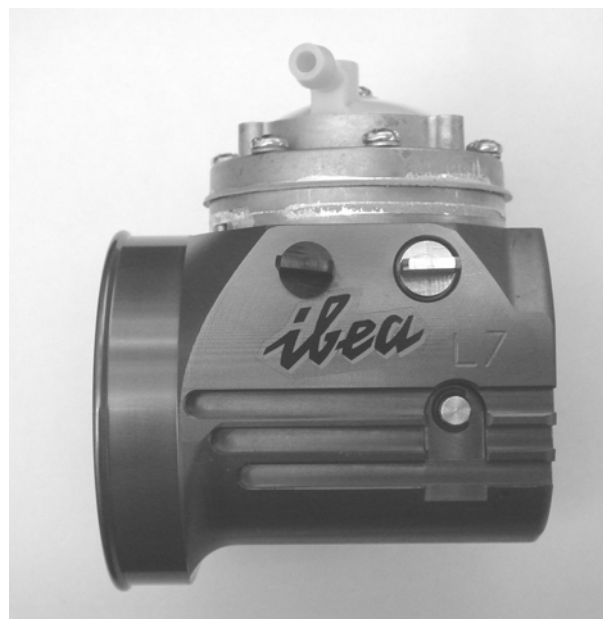

PHOTO CÔTÉ RÉGLAGE  
PHOTO OF ADJUSTING SIDE

Signature et tampon de l'ASN  
*Signature and stamp of the ASN*

Signature et tampon de la CIK-FIA  
*Signature and stamp of the CIK-FIA*

**auto sport**



*[Handwritten signature]*

VUE EN SECTION  
CONDUIT D'ASPIRATION  
INLET PORT SECTION VIEW

VUE DE FACE  
CÔTÉ ASPIRATION  
INLET SIDE FRONT VIEW

*Echelle 1:1 / 1:1 Scale*

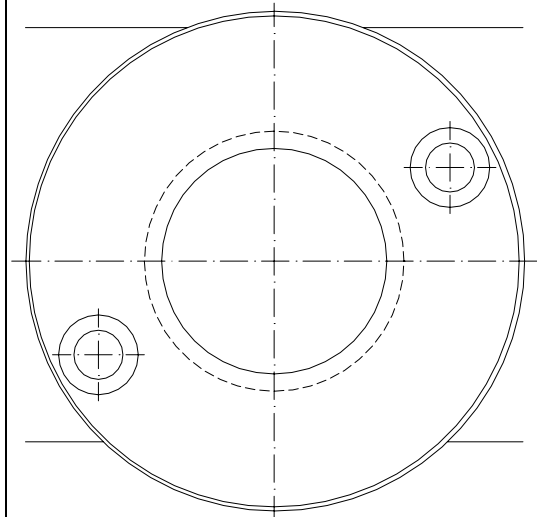
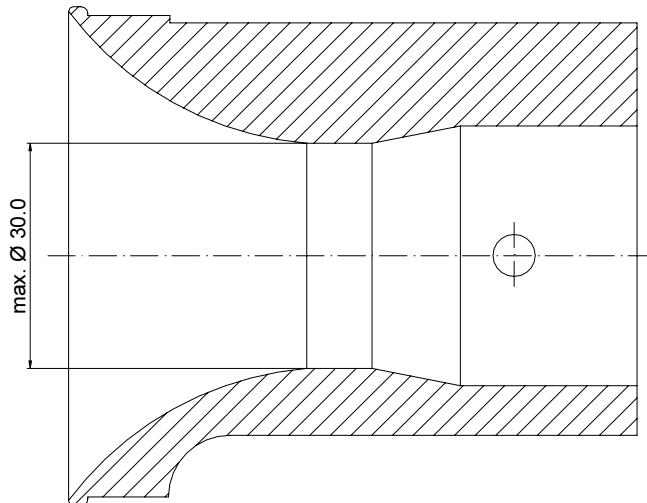

DESCRIPTION DU CARBURATEUR ET  
ESQUISSE DES PIÈCES

CARBURETTOR DESCRIPTION AND  
SKETCH OF PARTS

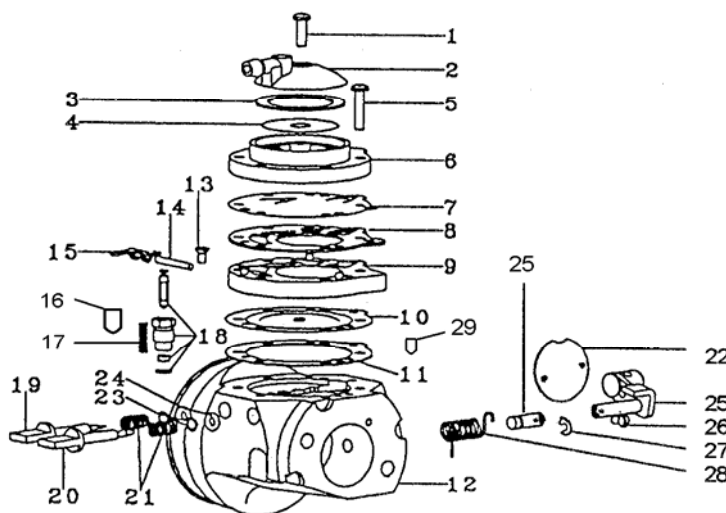

No:

- 1 Fuel Strainer Cover Screw
- 2 Fuel Strainer Cover
- 3 Fuel Strainer Gasket
- 4 Fuel Strainer Screen
- 5 Fuel Pump Screw
- 6 Fuel Pump Body
- 7 Fuel Pump Diaphragm
- 8 Fuel Pump Gasket
- 9 Diaphragm Cover
- 10 Diaphragm
- 11 Diaphragm Gasket
- 12 Carburettor Body
- 13 Inlet Control Lever Screw
- 14 Inlet Control Lever Fulcrum
- 15 Inlet Control Lever
- 16 H-Nozzle
- 17 Inlet Tension Spring
- 18 Inlet Needle Seat & Gasket
- 19 High Speed Mixture Screw
- 20 Idle Mixture Screw L
- 21 Idle Mixture Spring
- 22 Shutter
- 23 Idle Mixture Screw Washer
- 24 Idle Mixture Screw Packing
- 25 Shaft
- 26 Screw for Shutter
- 27 Shaft Clip
- 28 Spring for Shaft
- 29 L-Nozzle