

FICHE D'HOMOLOGATION HOMOLOGATION FORM



COMMISSION INTERNATIONALE
DE KARTING – FIA



CARBURATEUR / CARBURETTOR

Constructeur	<i>Manufacturer</i>	DINO A/S
Marque	<i>Make</i>	DINO
Modèle	<i>Model</i>	C17
Catégorie	<i>Category</i>	KF2 D24
Durée de l'homologation	<i>Validity of the homologation</i>	9 ans / 9 years
Nombre de pages	<i>Number of pages</i>	2

La présente Fiche d'Homologation reproduit descriptions, illustrations et dimensions du carburateur au moment de l'homologation CIK-FIA. Le Constructeur a la possibilité de les modifier seulement dans les limites fixées par le règlement CIK-FIA en vigueur.

This Homologation Form reproduces descriptions, illustrations and dimensions of the carburettor at the moment of the CIK-FIA homologation. The Manufacturer may modify them, but only within the limits fixed by the CIK-FIA regulations in force.



PHOTO CÔTÉ ASPIRATION
PHOTO OF INLET SIDE



PHOTO CÔTÉ RÉGLAGE
PHOTO OF ADJUSTING SIDE

Signature et tampon de l'ASN
Signature and stamp of the ASN

Signature et tampon de la CIK-FIA
Signature and stamp of the CIK-FIA

INTERNATIONAL SPORTS UNION
Hedehus Hus, DK-2605 Brøndby, Danmark
T: (+45) 44 25 22 26 F: (+45) 44 21 31



VUE EN SECTION
CONDUIT D'ASPIRATION
INLET PORT SECTION VIEW

VUE DE FACE
CÔTÉ ASPIRATION
INLET SIDE FRONT VIEW

Echelle 1:1 / 1:1 Scale

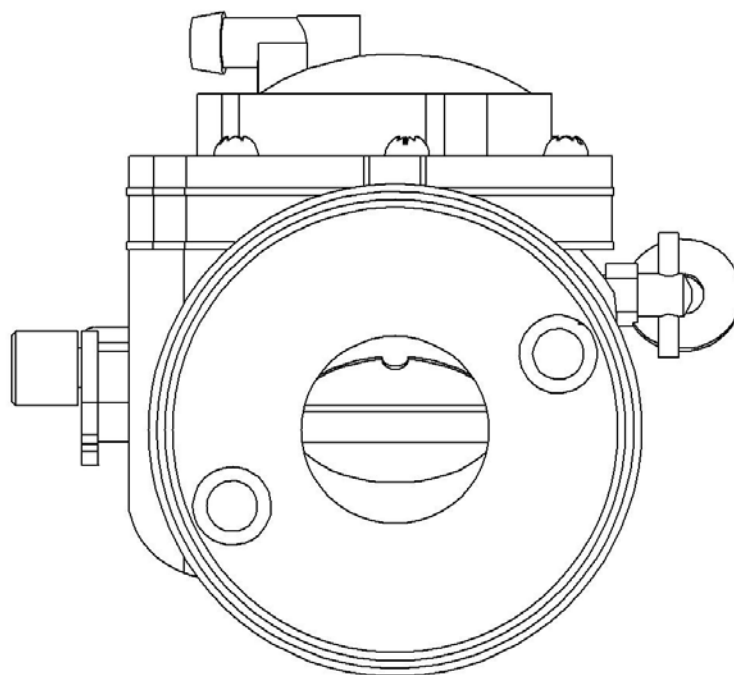
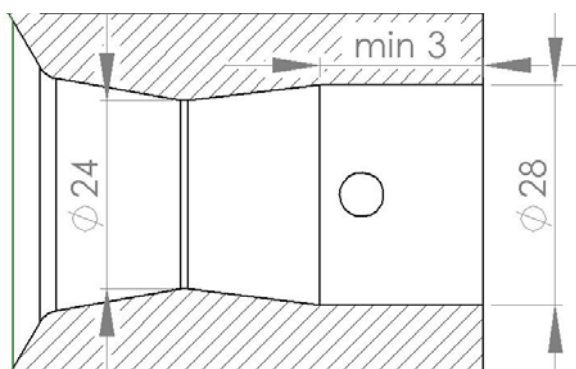

DESCRIPTION DU CARBURATEUR ET
ESQUISSE DES PIÈCES

CARBURETTOR DESCRIPTION AND
SKETCH OF PARTS

- 1 Carburettor body
- 2 Screw
- 3 Fuel cap
- 4 Gasket
- 5 Screw
- 6 Filter
- 7 Pump housing
- 8 Pump diaphragm
- 9 Gasket
- 10 Diaphragm cap
- 11 Diaphragm
- 12 Gasket
- 13 Screw
- 14 Pin
- 15 Inlet lever
- 16 Spring
- 17 Inlet valve
- 18 Washer
- 19 Valve housing
- 20 O-ring
- 21 Spring
- 22 H-screw
- 23 L-screw
- 24 Washer
- 25 Screw
- 26 Retainer
- 27 Screw
- 28 Throttle
- 29 Spring
- 30 Screw
- 31 Throttle axle

